

The print-out is not subject to the modification service.

Intended for internal and supplier use

EN

**RELEASE**  
 for supplier  
 company Zhang Shi

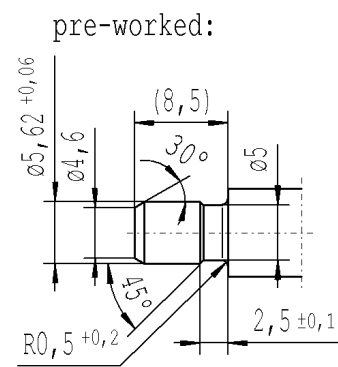
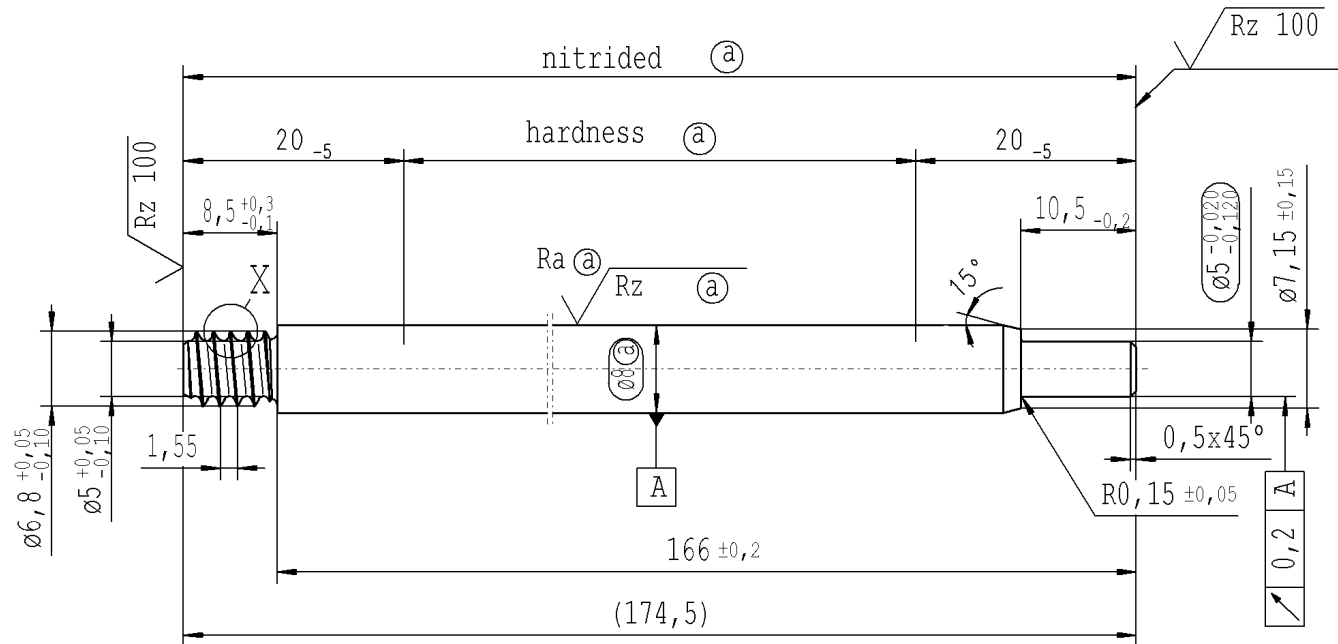

X 5:1

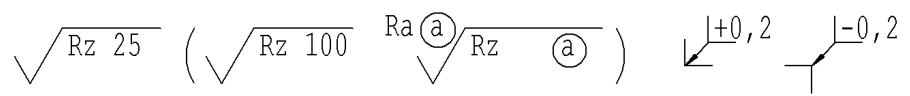
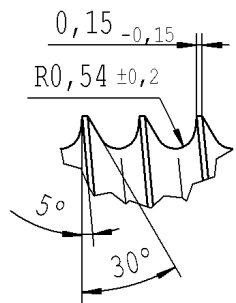

Environmental protection acc. to STAB-Spec. 10005649

DE: X	EN: X	ES:	IT:	PR:	FR:	RO:	CAD created document; handwritten changes not permitted	Material: 1.1193 S45C JISG 4051	All dimensions are in mm	Identification of important characteristics	Drawn by 19.05.2008 Hein	Date 19.05.2008	Name Klinkner
new	INITIAL RELEASE							Edge tolerances acc. to DIN ISO 13715	Scale: (Original DIN A3) 2:1	Dimensions without tolerances DIN ISO 2768-mK	Checked	21.05.2008	
old	-							Surface finish DIN EN ISO 1302	We reserve all rights to this document, to any patents or patent registrations related hereto, and to the duplication, retransmission by third parties and misc. use. Any use of this document is not permitted without the written consent of STABILUS.				
Field	-							Replaces:	Document No.: 10151065				
Date/Name	19.05.2008 Hein								Material No.: 0713WE				
Chg. No.	-							<b>STABILUS</b>	PISTON ROD				
Rev.	0												