

The print-out is not subject to the modification service.

Intended for internal and supplier use

EN

Ⓐ piston rod processing per STAB-Spec. 10028959, table 1

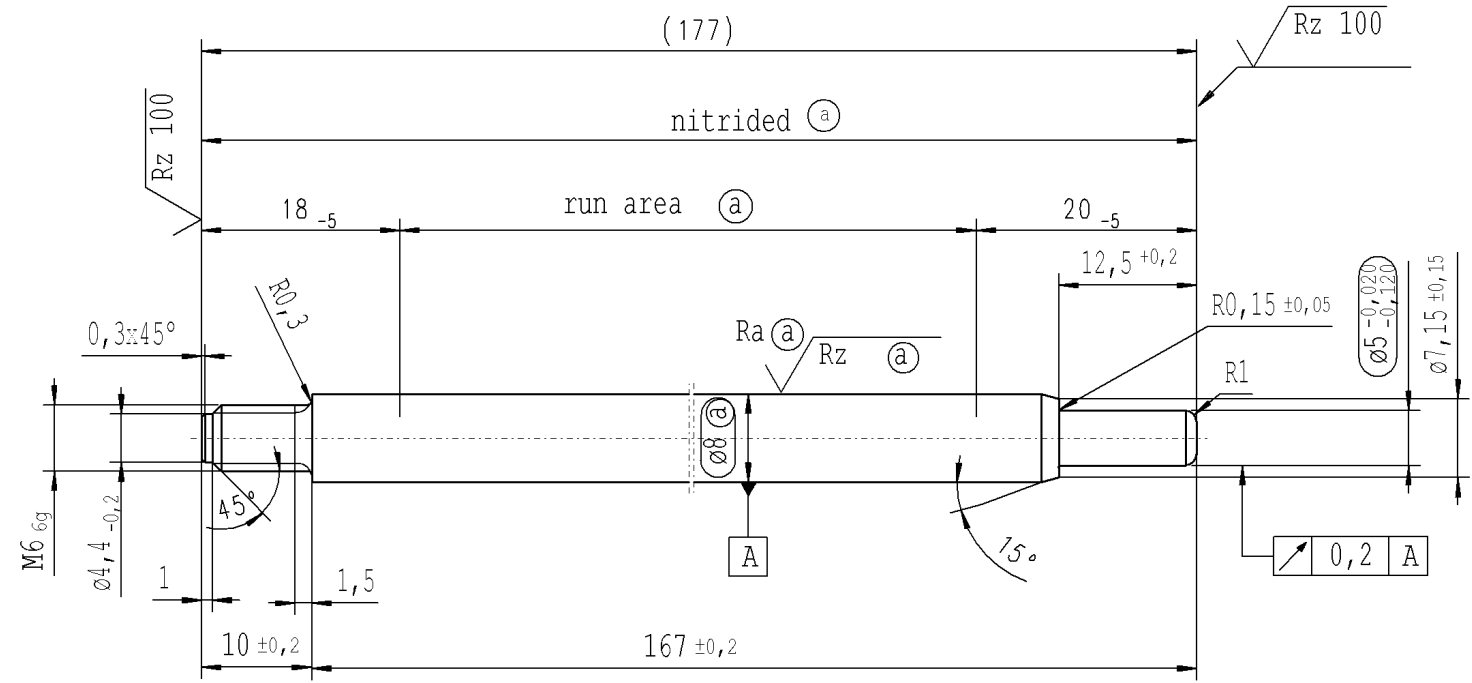

thread tolerances acc. to DIN ISO 965-3

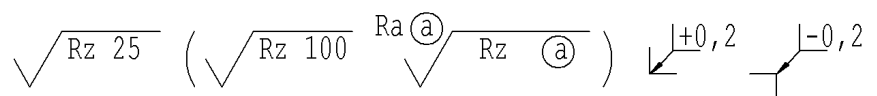

**RELEASE**  
for supplier  
company Zhang Shi  
29.04.2015 Schilz A.  
(date / signature)

AIAG CQI-standards acc. to STAB-Spec. 10027692

Environmental protection acc. to STAB-Spec. 10005649

DE: X	EN: X	ES:	IT:	PR:	FR:	RO:	CAD created document; handwritten changes not permitted	
new	INITIAL RELEASE			12,5 <sup>+0,2</sup>				
old	-			12,5 <sup>-0,2</sup>				
Field	-			E/2-3				
Date/Name	20.03.2015 Höfer		29.04.2015 Hein					
Chg. No.	622382		622382					
Rev.	0		1					

Material:	1.1193 S45C JISG 4051
Edge tolerances acc. to DIN ISO 13715	
Surface finish	DIN EN ISO 1302
Replaces:	
<b>STABILUS</b>	

All dimensions are in mm	Identification of important characteristics	Scale: (Original DIN A3) 2:1	Dimensions without tolerances DIN ISO 2768-mK
We reserve all rights to this document, to any patents or patent registrations related hereto, and to the duplication, retransmission by third parties and misc. use. Any use of this document is not permitted without the written consent of STABILUS.			
Document No.:		10221015	
Material No.:		993066	
PISTON ROD			

Date	Name
20.03.2015	Höfer
29.04.2015	Klinkner

Ident. Doc.: