

CAD-SYSTEM UNIGRAPHICS ID:pa\_04-7077\_de1/2

EN Intended for internal and supplier use The print-out is not subject to the modification service

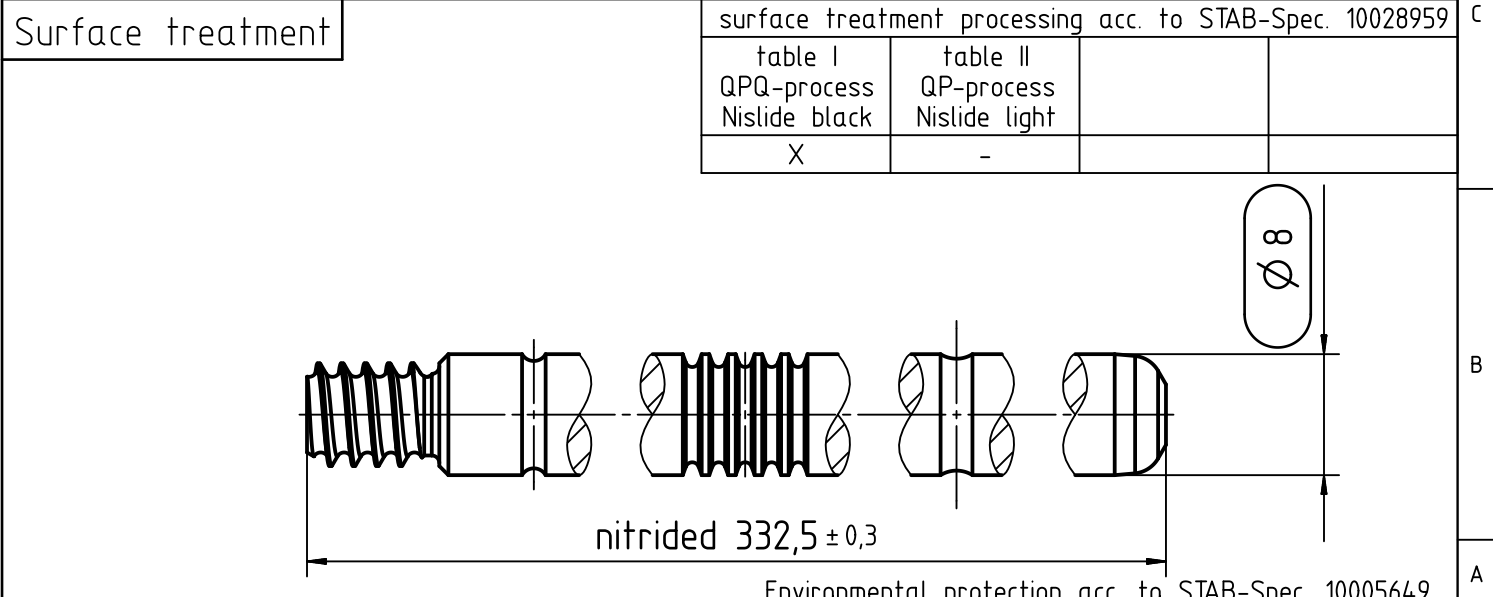
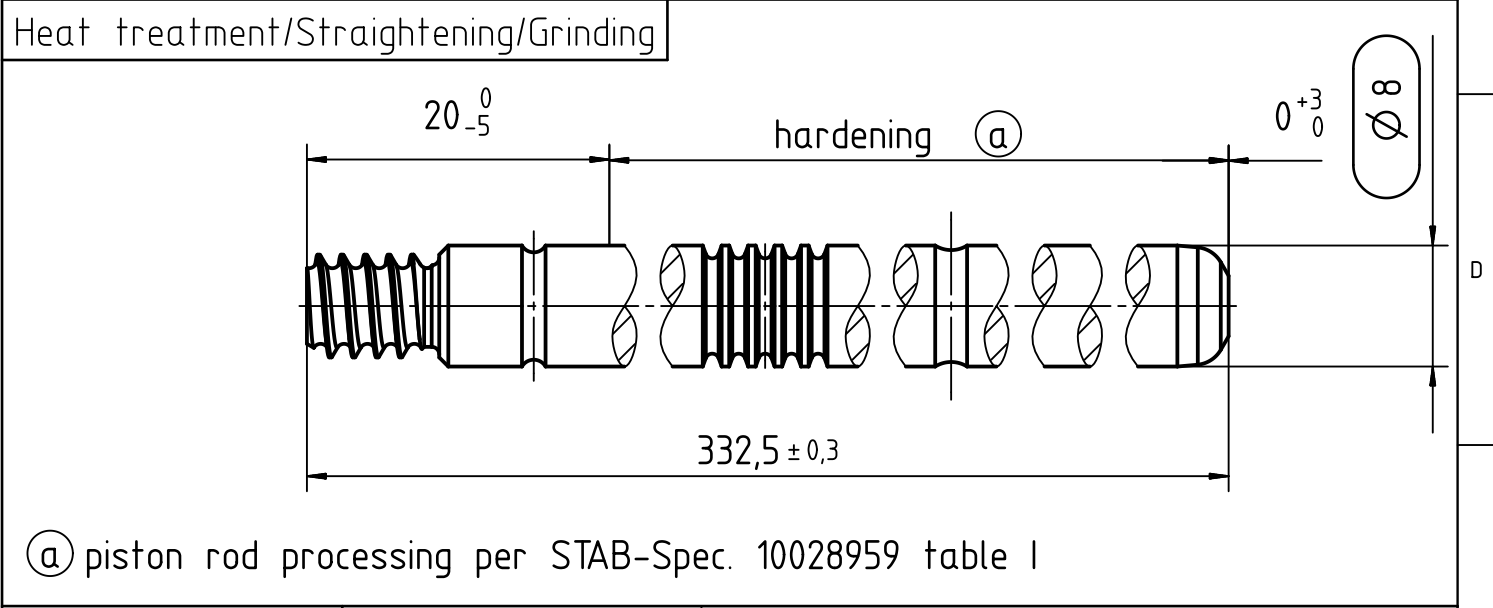
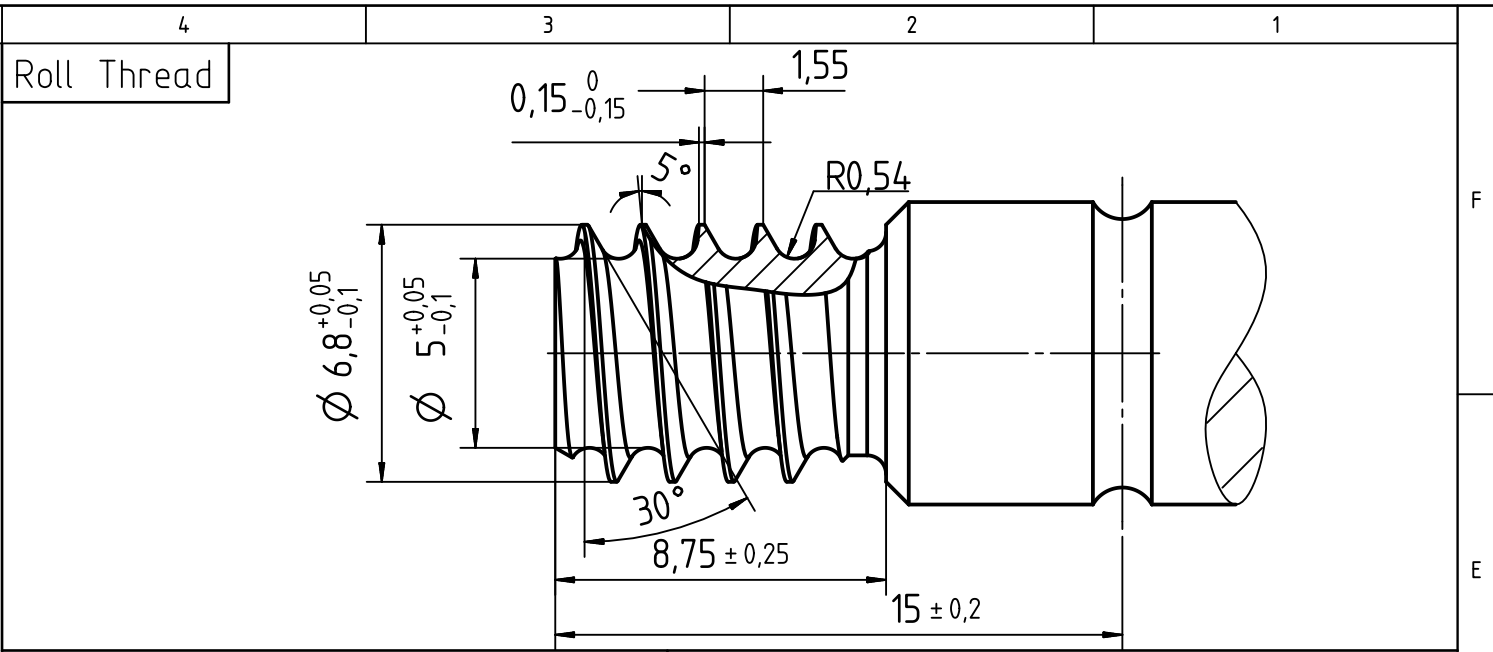
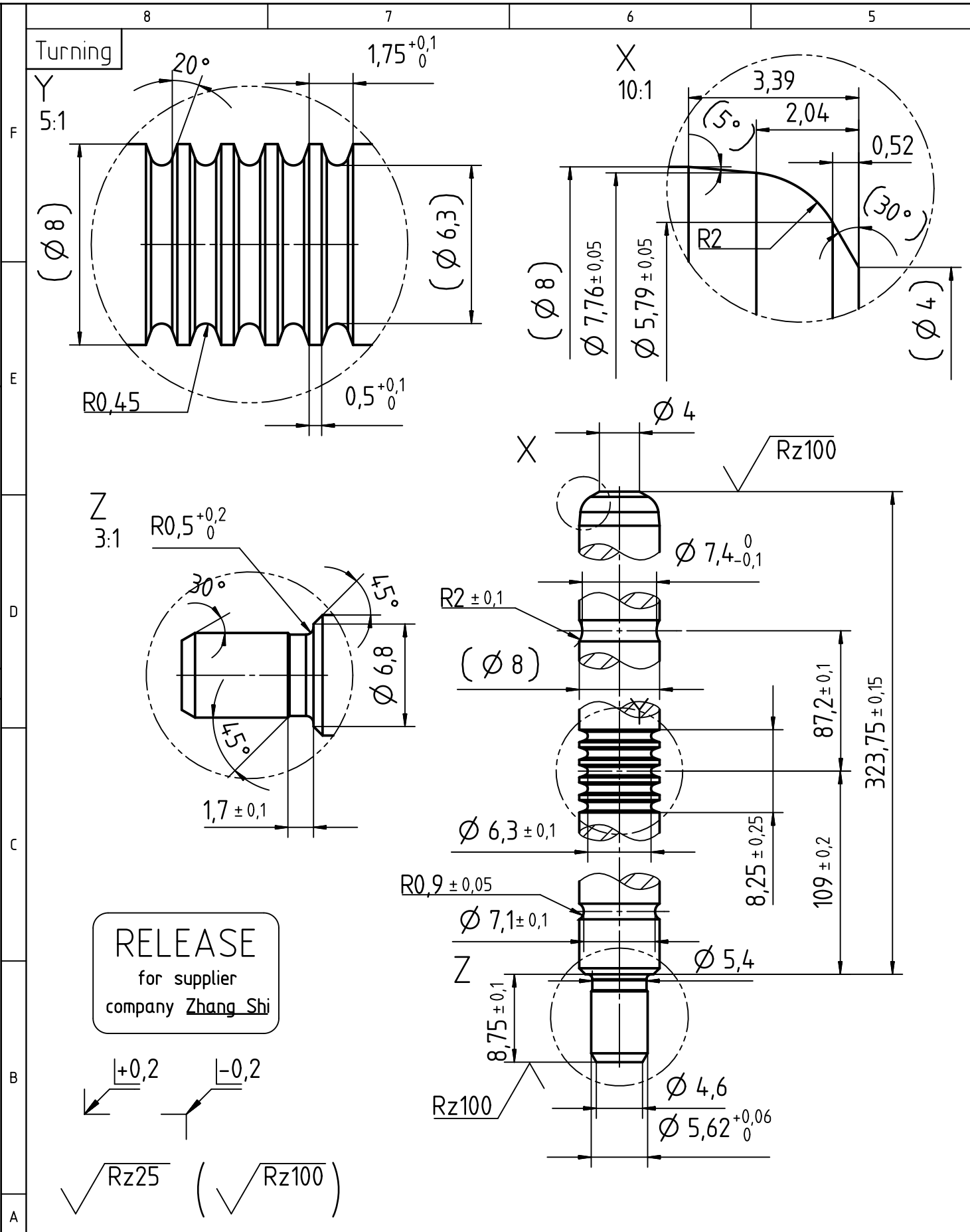

DE:	X	EN:	X	ES:		IT:		PT:		FR:		RO:	
new	length 332,5	old	length 332	Field	-	Date/Name	01.07.2008 Hoyer	Change No	566287	Revision	2		

Material:	1.1193 S45C JISG 4051	All dimensions are in mm	Identification of important characteristics
Edge tolerances acc. to DIN ISO 13715		Scale: (Original DIN A3) 2:1	Dimensions without tolerances DIN ISO 2768-mK
Surface finish	DIN EN ISO 1302	We reserve all rights to this document, to any patents or patent registrations related hereto, and to the duplication, retransmission by third parties and misc. use. Any use of this document is not permitted without the written consent of STABILUS. CAD created document; handwritten changes not permitted	
Replaces:	563918	Document No.: 10152056	
<b>STABILUS</b>		Material No.: 009443	

Material: 1.1193 S45C JISG 4051		All dimensions are in mm	Identification of important characteristics	Date	Name
Edge tolerances acc. to DIN ISO 13715		Scale: (Original DIN A3) 2:1	Dimensions without tolerances DIN ISO 2768-mK	Drawn by	18.01.2007 Huerter,A.
Surface finish: DIN EN ISO 1302		We reserve all rights to this document, to any patents or patent registrations related hereto, and to the duplication, retransmission by third parties and misc. use. Any use of this document is not permitted without the written consent of STABILUS. CAD created document; handwritten changes not permitted		Checked	01.07.2008 Hecken,U.
Replaces: 563918		Document No.: 10152056		Material No.: 009443	
<b>STABILUS</b>		PISTON ROD			