

The print-out is not subject to the modification service.

① piston rod processing per STAB-Spec. 10028959, table 1

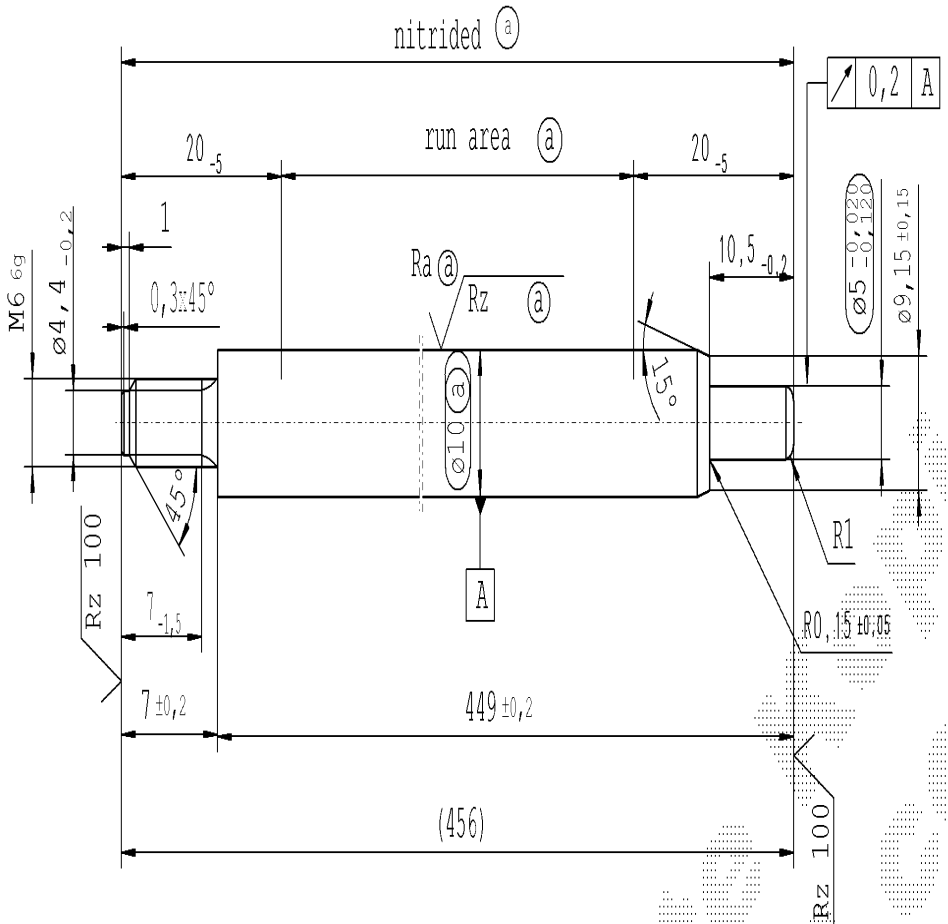

thread tolerances acc. to DIN ISO 965-3

$\sqrt{Rz\ 25}$ ($\sqrt{Rz\ 100}$ $\sqrt{Ra\ ①}$ $\sqrt{Rz\ ①}$) $\sqrt{+0,2}$ $\sqrt{-0,2}$

RELEASE
for supplier
company Zhang Shi
20.01.2016 Schilz A.
(date / signature)

AIAG CQI-standards acc. to STAB-Spec. 1002892 Environmental protection acc. to STAB-Spec. 10005649

DE: X	EN: X	ES:	IT:	PR:	FR:	RO:	CAD created document; handwritten changes not permitted	Material: 1.1193 S45C JISG 5051	All dimensions are in mm	Identification of important characteristics	Date	Name
new	INITIAL RELEASE							Edge tolerances acc. to DIN ISO 13715	Scale: (Original DIN A3) 2:1	Dimensions without tolerances DIN ISO 2768-mK	20.01.2016	Höfer
old	-							Surface Finish: DIN EN ISO 1302			20.01.2016	Milles
Field	-							Applic.: STABILUS	We reserve all rights to this document, to any patents or patent registrations related hereto, and to the duplication, retransmission by third parties and misc. use. Any use of this document is not permitted without the written consent of STABILUS.			Document No.: 10160325
Date/Name	20.01.2016 Höfer								PISTON ROD			Material No.: 346097
Chg. No.	632698											
Rev.	0											