

The print-out is not subject to the modification service.

Intended for internal and supplier use

EN

Ⓐ piston rod processing per STAB-Spec. 10028959, table 1

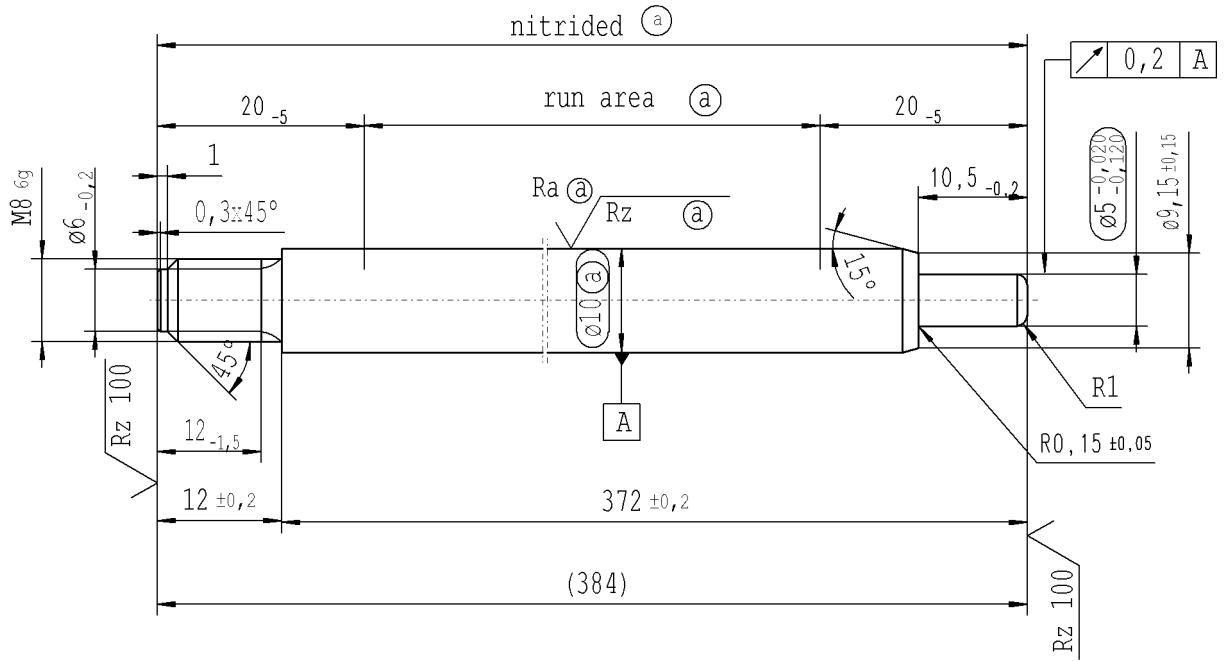

thread tolerances acc. to DIN ISO 965-3

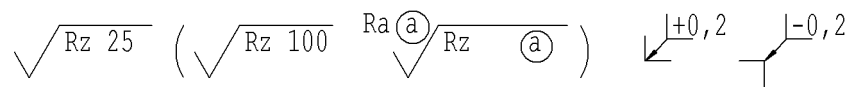

AIAG CQI-standards acc. to STAB-Spec. 10027692

Environmental protection acc. to STAB-Spec. 10005649

Ident. Doc.: L32

DE: X	EN: X	ES:	IT:	PR:	FR:	RO:
new	INITIAL RELEASE			12		
old	-			10		
Field	-			D6		
Date/Name	18.01.2016 Höfer			29.02.2016 Höfer		
Chg. No.	632608			634598		
Rev.	0			1		

CAD created document; handwritten changes not permitted

Material: 1.1193  
S45C JISG 4051

Edge tolerances acc. to DIN ISO 13715

Surface finish DIN EN ISO 1302

Replaces:

**RELEASE**  
for supplier

company Zhang Shi

Dat. 29.02.2016 Schilz A.  
(date / signature)

**STABILUS**

All dimensions are in mm

Scale: (Original DIN A3) 2:1

Identification of important characteristics

Dimensions without tolerances DIN ISO 2768-mK

We reserve all rights to this document, to any patents or patent registrations related hereto, and to the duplication, retransmission by third parties and misc. use. Any use of this document is not permitted without the written consent of STABILUS.

Document No.: 10166619

Material No.: 323870

PISTON ROD

Drawn by	18.01.2016	Höfer
Checked	29.02.2016	Milles