

All rights are reserved in accordance with ISO 16016.
Copying of this document and the use only with authorization.
Contravention commits to damage compensation.

Tolerances for dimensions without individual tolerance indications according to DIN ISO 2768-mH

DIN EN ISO 1302	$\sqrt{Ra 0.2}$	$\sqrt{Rz 2.5}$	$\sqrt{Rz 6.3}$	$\sqrt{Rz 1}$
	$\sqrt{Ra 0.4}$	$\sqrt{Rz 5}$	$\sqrt{Rz 12.5}$	$\sqrt{Rz 0.5}$

above /	above /	above /	above /	above /
0.5	6	30	120	400
±0.1	±0.2	±0.3	±0.5	±0.8

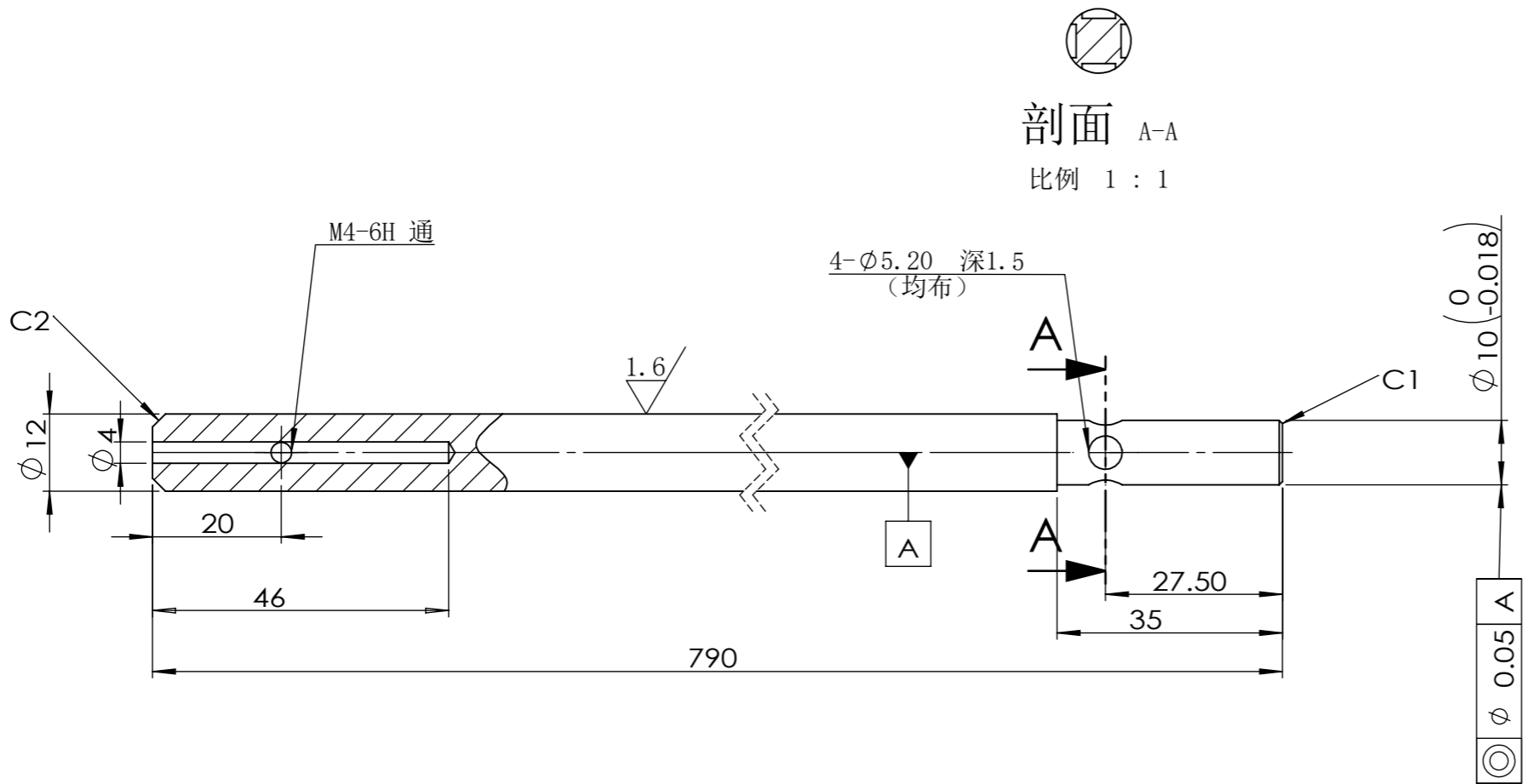

1. 锐边倒角C0.5
2. 其余 $\sqrt{3.2}$

	更换:				注:	
	替换:					
	材料: 40Cr	粗糙度: $\sqrt{3.2}$	表面处理:	热处理: 调质处理		HRC 28以上
	日期: 16 04 06	设计: 李龙凡	零件名称: 吹净机毛刷杆			
比例: 1:1	执行标准(e)E: ISO 128-30	页数: 共1页	零件号:	版本:	仅修改用CAD	