

CONFIDENTIAL!  
Intended for internal use only

Ident. Doc.:  
Errelelledatum: 8/4/2016 - 9:30

| F | supp. No. | material no.                                    |                 |                                | A     | E     | F |
|---|-----------|---|-----------------|--------------------------------|-------|-------|---|
|   |           | surface treatment processing acc. to STAB-Spec. |                 |                                |       |       |   |
|   |           | 10006248 Tab. IV                                | 10006248 Tab. X | 10028959 Tab. I China pay part |       |       |   |
|   | 35        | 084147  | 084147          | 084147                         | 216.0 | 207.5 | 1 |
|   | 36        | 913238  | 913238          | 913238                         | 300.0 | 291.5 | 1 |
|   | 37        | 914433  | 914433          | 914433                         | 201.0 | 192.5 | 1 |
|   | 38        | 974900  | 974900          | 974900                         | 261.0 | 252.5 | 1 |
|   | 39        | 999517  | 999517          | 999517                         | 262.5 | 254.0 | 1 |
|   | 40        |   | 079129          | 079129                         | 231.0 | 222.5 | 1 |
|   | 41        | 908937  | 908937          | 908937                         | 354.0 | 345.5 | 1 |
|   | 42        | 084388  | 084388          | 084388                         | 204.0 | 195.5 | 1 |
|   | 43        | 848710  | 848710          | 848710                         | 186.0 | 177.5 | 1 |
|   | 44        | 338924  | 338924          | 338924                         | 228.0 | 219.5 | 1 |
|   | 45        | 423533  | 423533          | 423533                         | 102.0 | 93.5  | 1 |
|   | 46        | 424011  | 424011          | 424011                         | 402.0 | 393.5 | 1 |
|   | 47        | 424250  | 424250          | 424250                         | 501.0 | 492.5 | 1 |
|   | 48        | 424489  | 424489          | 424489                         | 600.0 | 591.5 | 1 |
|   | 49        | 216559  | 216559          | 216559                         | 240.0 | 231.5 | 1 |
|   | 50        | 243805  | 243805          | 243805                         | 351.0 | 342.5 | 1 |
|   | 51        | 275114  | 275114          | 275114                         | 357.0 | 348.5 | 1 |
|   | 52        | 290649  | 290649          | 290649                         | 150.0 | 141.5 | 1 |
|   | 53        | 330801  | 330801          | 330801                         | 249.5 | 241.0 | 1 |
|   | 54        | 336298  | 336298          | 336298                         | 249.0 | 240.5 | 1 |
|   | 55        | 344185  | 344185          | 344185                         | 303.0 | 294.5 | 1 |
|   | 56        | 372148  | 372148          | 372148                         | 312.0 | 303.5 | 1 |
|   | 57        | 108054  | 108054          | 108054                         | 333.0 | 324.5 | 1 |
|   | 58        |   | 540644          | 540644                         | 378.0 | 369.5 | 1 |
|   | XX        | XXXXX   | XXXXXX          | XXXXXXX                        | 294   | 285.5 | 1 |

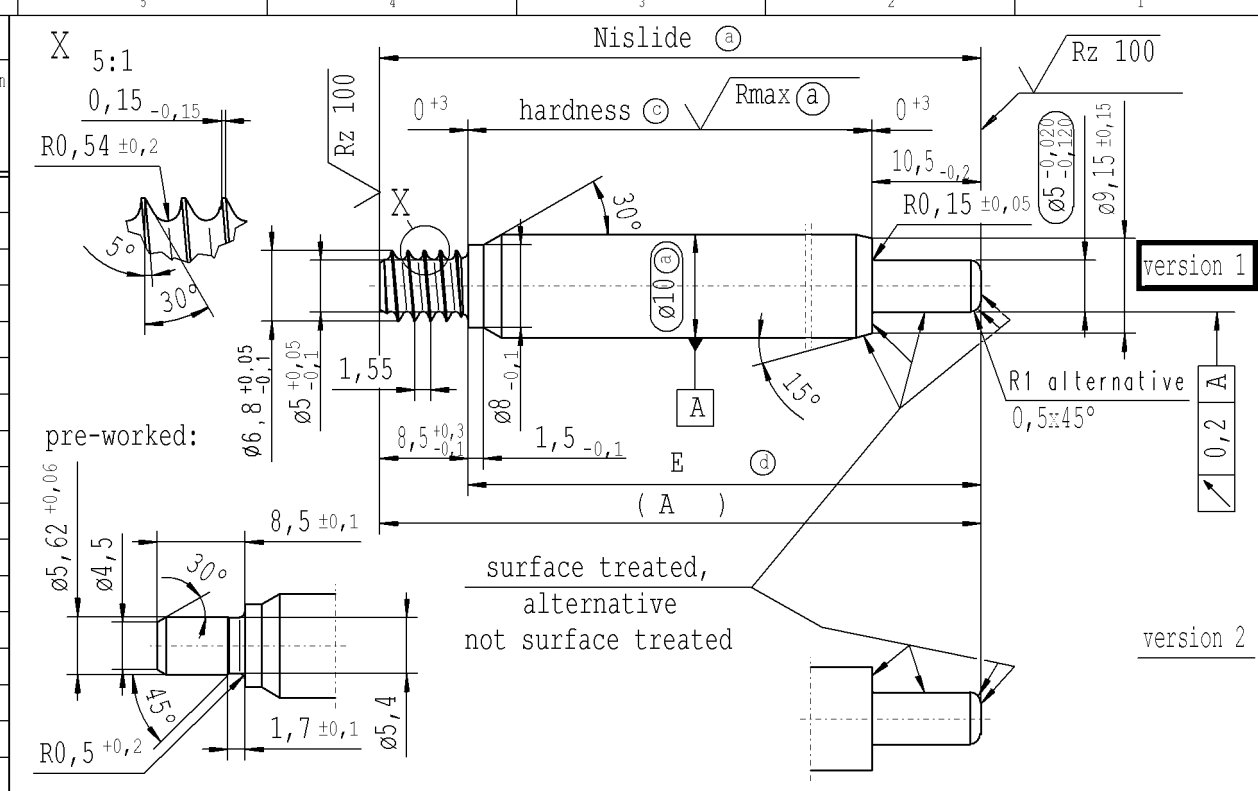

Production Stabilus

(a) piston rod processing acc. to STAB-Spec. 10006248

(c) RHT 0,4..0,7 mm before grinding, > 68 HRA (acc. to DIN ISO 6508);

(d) tolerances:  $\begin{matrix} +0,2 \\ -0,1 \end{matrix}$  after turning;  
 $\begin{matrix} +0,3 \\ -0,1 \end{matrix}$  after straightening;  
 $\pm 0,3$  after nisliding

Pay part China acc separate Supplier-drawing

for pay part China product family: 2008/0024 approved lengths: 100-600 mm

\* only Tab. IV

$\sqrt{Rz 25}$  ( $\sqrt{Rz 100}$   $\sqrt{Rmax (a)}$ )

sheet 2  
Höfer

|           |             |                          |     |     |                         |                             |   |                        |                 |                                       |  |   |   |            |               |          |
|-----------|-------------|--------------------------|-----|-----|-------------------------|-----------------------------|---|------------------------|-----------------|---------------------------------------|--|---|---|------------|---------------|----------|
| DE: X     | EN: X       | ES:                      | IT: | PR: | FR:                     | RO:                         | CAD created document; handwritten changes not permitted |                        |                 |                                       | Material:  | All dimensions are in mm                      | Identification of important characteristics | Date       | Name          |          |
| new       | Version 2   | text: product family ... |     |     | $\phi 5^{+0,05}_{-0,1}$ | approved lengths:100-600 mm | R1 alternative 0,5x45°                                  | split column Tab. IV+X |                 | mat.no. 010715                        | Scale: (Original DIN A3) 2:1   | Dimensions without tolerances DIN ISO 2768-mK | Drawn by                                    | 17.12.2007 | Höfer         |          |
| old       | Version 3   | -; dimension B           |     |     | $\phi 5^{+0,3}$         | approved lengths:150-400 mm | 0,5x45°   | -                      |                 | Edge tolerances acc. to DIN ISO 13715 |  |   | Checked                                     | 19.07.2010 | Klinkner      |          |
| Field     | B-D,1-2     | B/C 1/2; A-F7            |     |     | E-F/4                   | B-C/2-3                     |   | E/1-2                  | A-F/7-8         | Surface finish DIN EN ISO 1302        | We reserve all rights to this document, to any patents or patent registrations related hereto, and to the duplication, retransmission by third parties and misc. use. Any use of this document is not permitted without the written consent of STABILUS. |   |   |            | Document No.: | 10151520 |
| Date/Name | 11.03.08 Hö | 15.04.2008 Hein          |     |     | 15.04.2008 Hein         | 20.01.2009 Hein             |   | 18.02.2009 Hein        | 19.07.2010 Hein | Replaces:                             |  |   |   |            | Material No.: |          |
| Chg. No.  | 564241      | 564472                   |     |     | 565635                  | 570658                      |   | 571072                 | 581620          | <b>STABILUS</b>                       | <b>PISTON ROD</b>  |   |   |            |               |          |
| Rev.      | 2           | 3                        |     |     | 4                       | 5                           |   | 6                      | 7               |                                       |  |   |   |            |               |          |