

CONFIDENTIAL!
Intended for internal use only

supp. No.	material no.			A	E	Rifa
	surface treatment processing acc. to STAB-Spec.			overall length	length without endfitting stud	
	10006248 Tab. IV	table V Nislide light	10006248 Tab. X	10028959 Tab. I China pay part		
188	919685		919685	919685	279.0	270.5
189	991863		991863	991863	327.0	318.5
190	402968		402968	402968	306.0	297.5
191	403207		403207	403207	177.0	168.5
192	747845		747845	747845	333.0	324.5
193	902956		902956	902956	348.0	339.5
194	547086		547086	547086	111.0	102.5
195		692159		692159	309.0	300.5
196	694310		694310	694310	366.0	357.5
197	307848		307848	307848	334.0	325.5
198	529879		529879	529879	162.0	153.5
199	227068		227068	227068	315.0	306.5
200	248578		248578	248578	261.0	252.5
201	869261		869261	869261	105.0	96.5
202	103267		103267	103267	369.0	360.5
203	223723		223723	223723	186.0	177.5
204			163735	163735	228.0	219.5
205	721561		721561	721561	204.0	195.5
206	961995		961995	961995	157.5	149.0
207			056186	056186	212.5	204.0
208			061683	061683	157.5	149.0
209	907504		907504	907504	114.0	105.5
210	356610		356610	356610	417.0	408.5
211	859228		859228	859228	357.0	348.5
212	236873		236873	236873	203.0	194.5
213	723716		723716	723716	156.0	147.5
214	439785		439785	439785	102.0	93.5
215	440024		440024	440024	402.0	393.5
216	450301		450301	450301	501.0	492.5
Z17	450540		450540	450540	600.0	591.5

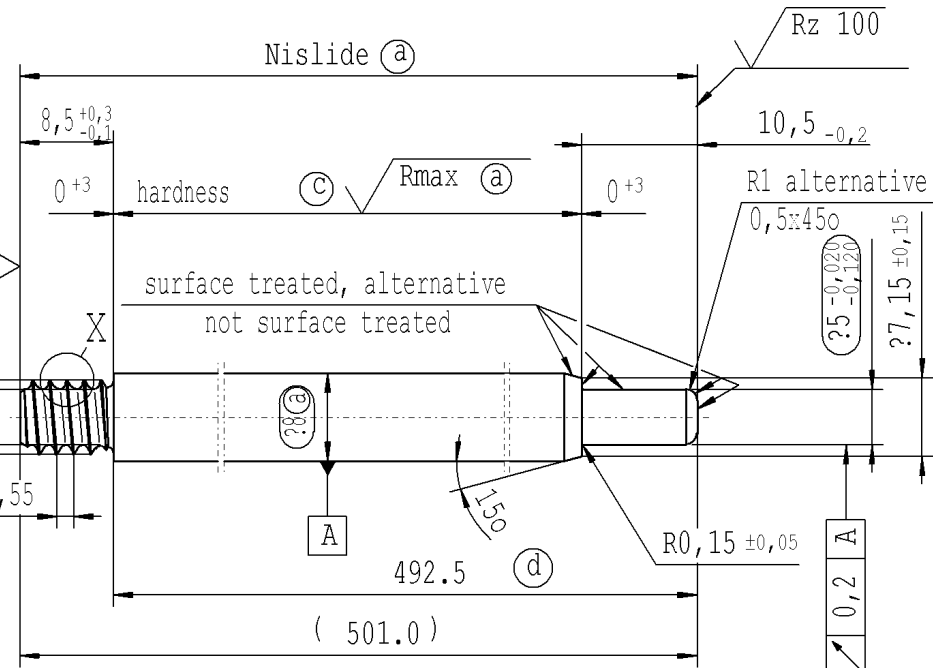
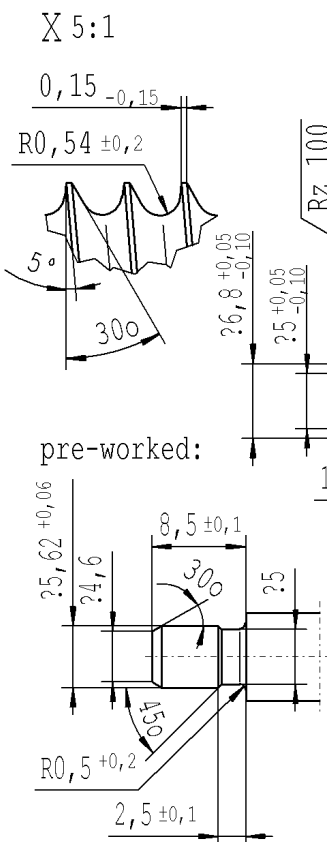

Production Stabilus

- (a) piston rod processing acc. to STAB-Spec. 10006248
- (c) RHT 0,4..0,7 mm before grinding, ≥ 68 HRA (acc. to DIN ISO 6508)
- (d) tolerances: $\begin{matrix} +0,2 \\ -0,1 \\ +0,3 \\ +0,3 \end{matrix}$ after turning
 $\begin{matrix} +0,3 \\ +0,3 \end{matrix}$ after straightening
 $\begin{matrix} +0,3 \\ +0,3 \end{matrix}$ after nisliding

Pay part China acc. separate Supplier drawing

Zhang Shi product family: 2008/0028 approved lengths: 100-600 mm	Rifa ** product family: 2014/0542 approved lengths: 100-600 mm
---	---

* only Tab. IV

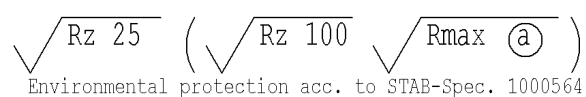
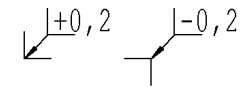

sheet 7
of 8

Environmental protection acc. to STAB-Spec. 10005649

Ident. Doc.:
Date: 19/2/2016 - 13:32

DE: X	EN: X	ES:	IT:	PR: X	FR:	RO:	CAD created document handwritten changes not permitted			Material:	All dimensions are in mm		Identification of important characteristics		Date	Name
new	-	column Tab. V added	UN	Text: ...Rifa	2014/0542	approved lengths: 100-600mm	mat.no. 010731			Scale: (Original DIN A3) 2:1		Dimensions without tolerances DIN ISO 2768-mK		Drawn by	H?fer	
old	TEC 006/08	-	305460311913	-	-	approved lengths: 100-450mm	Edge tolerances acc. to DIN ISO 13715			Surface finish DIN EN ISO 1302		Replaces:		Checked	25.11.2015	Klinkner
Field	C3-4	table	Pos. 201202	B-C/1-4	B-C/1-2	B/2	Replaces:			We reserve all rights to this document, to any patents or patent registrations related hereto, and to the duplication, retransmission by third parties and misc. use. Any use of this document is not permitted without the written consent of STABILUS.		Document No.:		10151065		
Date/Name	03.09.2013 Kron	01.10.2013 Kron	03.07.2014 H?fer	27.10.2014 H?fer	07.11.2014 H?fer	24.11.2015 Hein	Replaces:			Material No.:		PISTON ROD				
Chg. No.	605542	607210	614772	618028	618355	630576	Replaces:			Material No.:		PISTON ROD				
Rev.	9	10	11	12	13	14	Replaces:			Material No.:		PISTON ROD				

STABILUS

PISTON ROD