

Ident. Doc.: L01

① piston rod processing per STAB-Spec. 10028959, table 1

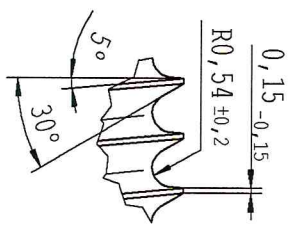
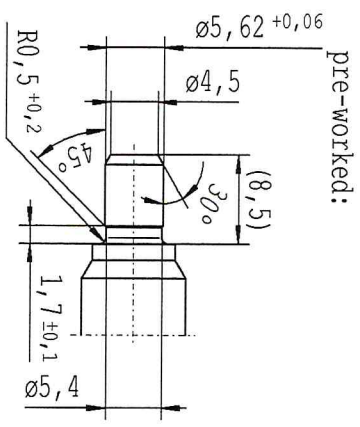
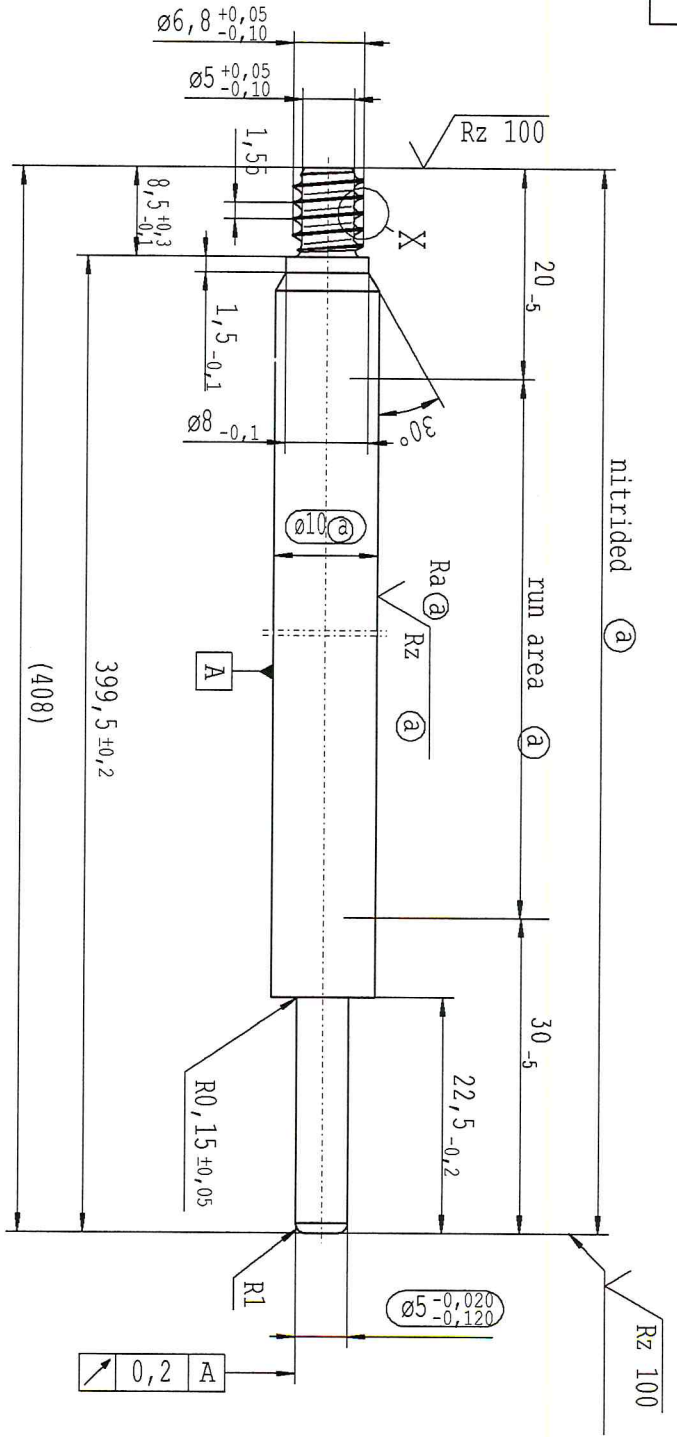

√ Rz 25 (√ Rz 100) Ra 0.2 (Rz 1) √ +0,2 -0,2

ALIG QLI-standards acc. to STAB-Spec. 10027692

CMO created document; handwritten changes not permitted

DF: X	EN: X	ES:	IT:	PR:	FR:	RO:
new	INITIAL RELEASE					
old	-					
Date/Name	18.07.2016	Höler				
Chg. No.	641737					
Rev.	0					

RELEASE
for supplier
company Zhang Shi
Date 19.07.2016
Schnitz A.

Material: 1.1193
S45C JISG 4051
Edge tolerances acc. to DIN ISO 13715
Surface finish DIN EN ISO 1302
Replaces: **STABILUS**

Environmental protection acc. to STAB-Spec. 10005649
All dimensions are in mm
Scale: (Original DIN A3) 2:1
Dimensions without tolerances
DIN ISO 2768 mK
We reserve all rights to this document, to any patents or patent registrations related hereto, and to the duplication, retransmission, publication without the written consent of STABILUS.

PISTON ROD

Document No.: 10235942
Material No.: 894124
Date: 18.07.2016
Checked: 19.07.2016
Name: Höler