

The print-out is not subject to the modification service.

Intended for internal and supplier use

EN

B

Ident. Doc.:

Ⓐ piston rod processing per STAB-Spec. 10028959, table 1

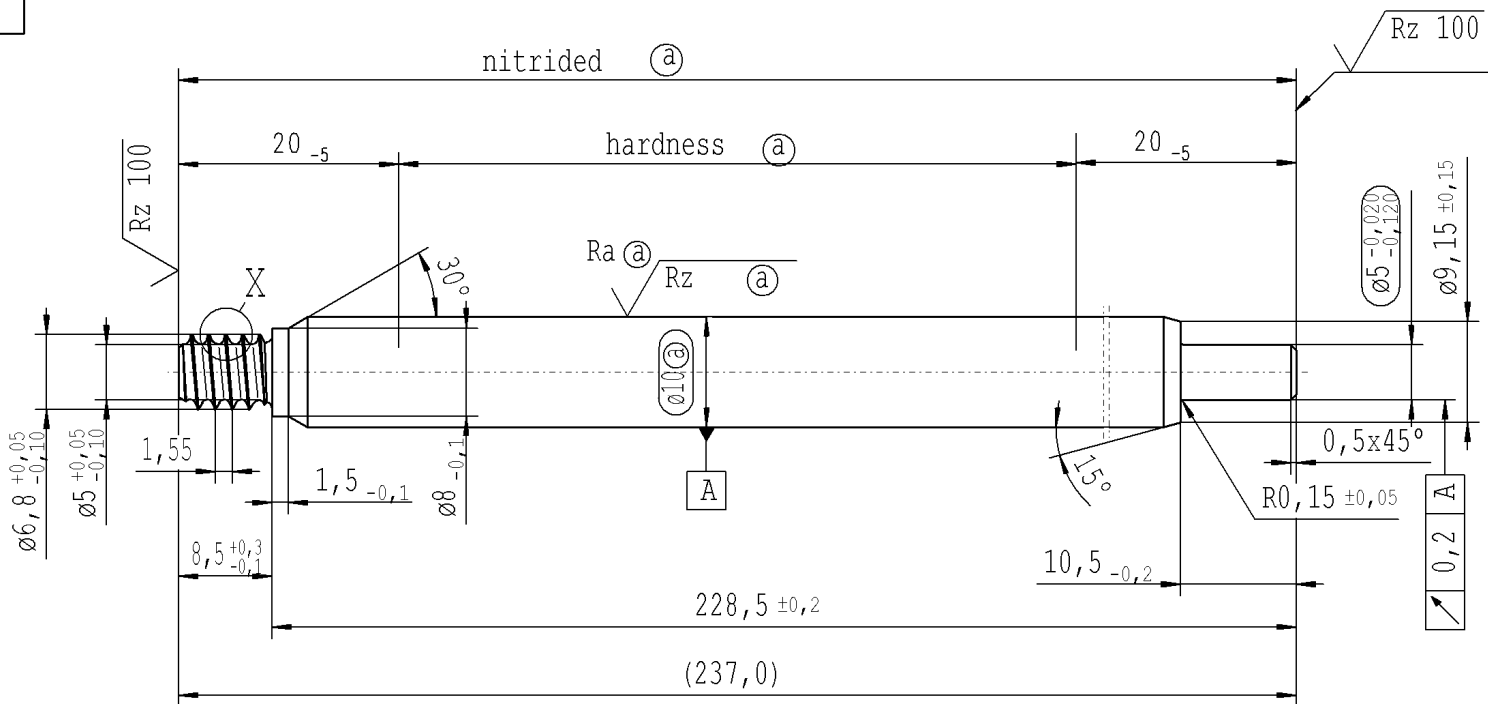

RELEASE  
for supplier  
company Zhang Shi

pre-worked:

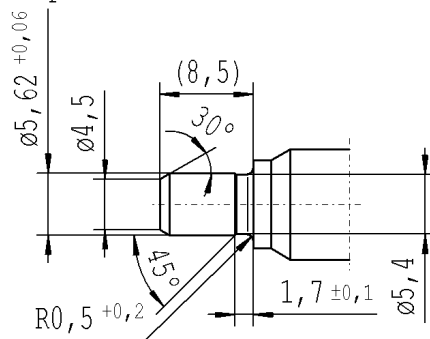

X 5:1

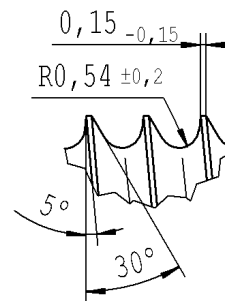

$\sqrt{Rz\ 25}$  (  $\sqrt{Rz\ 100}$   $Ra\ \text{Ⓐ}$   $Rz\ \text{Ⓐ}$  )  $\swarrow +0,2$   $\searrow -0,2$

Environmental protection acc. to STAB-Spec. 10005649

DE: X	EN: X	ES:	IT:	PR:	FR:	RO:	CAD created document; handwritten changes not permitted
new	INITIAL RELEASE						
old	-						
Field	-						
Date/Name	04.08.2009 Hein						
Chg. No.	-						
Rev.	0						

Material:	1.1193 S45C JISG 4051
Edge tolerances acc. to DIN ISO 13715	
Surface finish	DIN EN ISO 1302
Replaces:	
<b>STABILUS</b>	

All dimensions are in mm	Identification of important characteristics
Scale: (Original DIN A3) 2:1	Dimensions without tolerances DIN ISO 2768 mK
We reserve all rights to this document, to any patents or patent registrations related hereto, and to the duplication, retransmission by third parties and misc. use. Any use of this document is not permitted without the written consent of STABILUS.	

Drawn by	Date	Name
Checked	04.08.2009	Hein
Document No.:	10151520	
Material No.:	033744	