

Ⓐ piston rod processing per STAB-Spec. 10028959, table 1

The print-out is not subject to the modification service.

Intended for internal and supplier use

EN

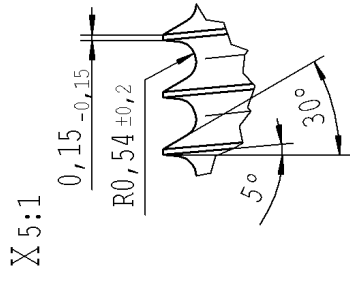
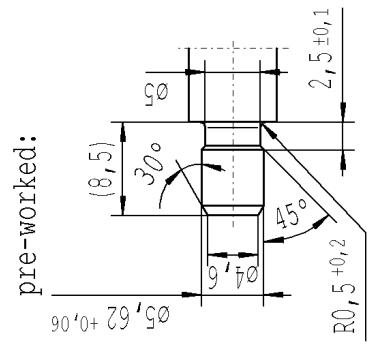
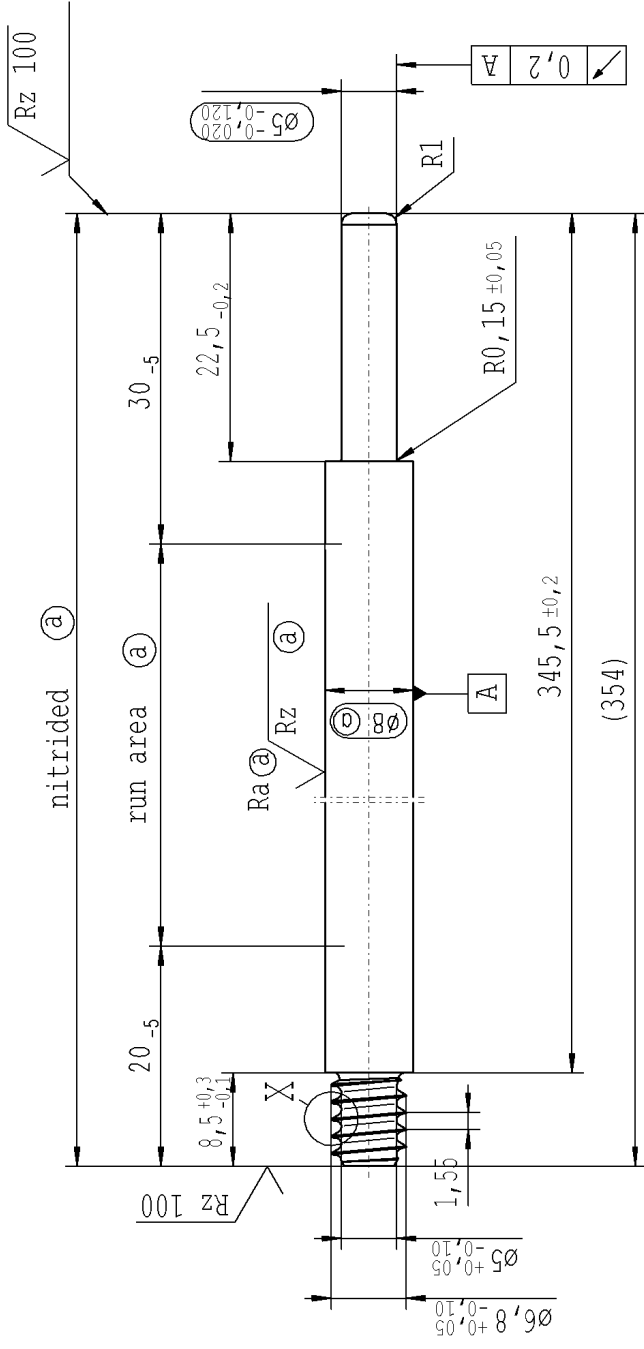

$\sqrt{Rz\ 25}$ ($\sqrt{Rz\ 100}$ $Ra\ \text{Ⓐ}$ $Rz\ \text{Ⓐ}$) $\downarrow +0,2$ $\downarrow -0,2$

A		AIAG CQI-standards acc. to STAB-Spec. 10027692		Material: 1.1193		Environmental protection acc. to STAB-Spec. 10005649	
B		CAD created document; handwritten changes not permitted		S45C JISG 4051		All dimensions are in mm	
C		RELEASE for supplier		Edge tolerances acc. to DIN ISO 13715		Identification of important characteristics	
D		company Zhang Shi		Surface finish DIN EN ISO 1302		Scale: (Original DIN A3) 2:1	
E		Date/Name 18.07.2016 Höfer		Replaces:		Dimensions without tolerances DIN ISO 2768-mK	
F		Chg. No. 641736		Dat. 18.07.2016 Schilz A.		We reserve all rights to this document, to any patents or patent registrations related hereto, and to the duplication, retransmission by third parties and aisc. use. Any use of this document is not permitted without the written consent of STABILUS.	
7		0		Date / signature		Document No.: 10154879	
8		INITIAL RELEASE		Date 18.07.2016		Material No.: 888866	
9		-		Name Höfer		Name Höfer	
10		-		Checked		Checked	
11		-		Date 18.07.2016		Date 18.07.2016	
12		-		Material No. 10154879		Material No. 888866	
13		-		Document No. 10154879		Document No. 10154879	
14		-		Material No. 888866		Material No. 888866	