

N1 N2

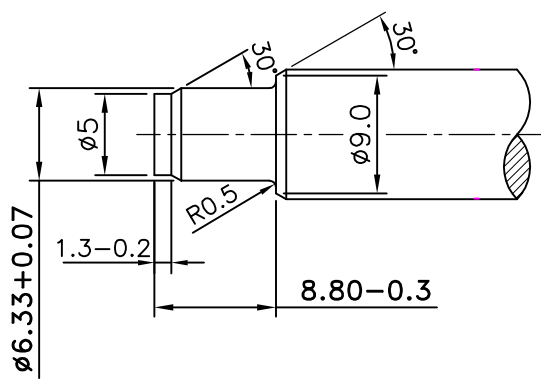

N1

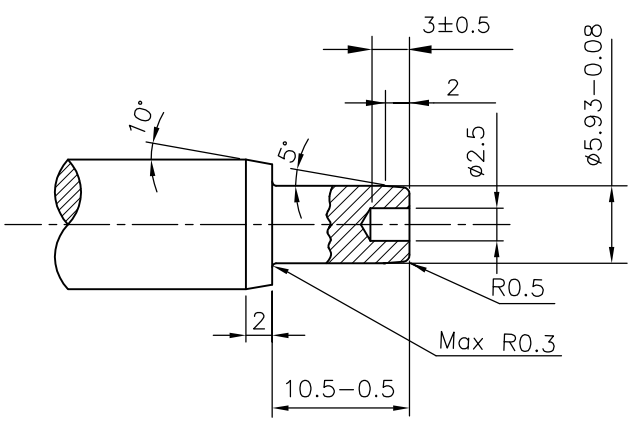

N3	TENIFER COATING WITH COMPOUND LAYER 10 TO 20μ
N2	TOL. IN STRAIGHTNESS TO STS-0007.
N1	ALL DIMNS. ARE IN MM.

NOTES

○	=CONTROLLED MEASUREMENT
()	=MEASUREMENT FOR REF. ONLY
[]	=PRE-MACHINING/RAW MATL. MEASUREMENT (REF.)

01/01	16.08.2017	THREAD SIZE CHANGED FROM M8 TO M7			
01/00	21.10.2016	INITIAL RELEASE	Sd/gv	Sd/MS	Sd/KS
ISS/REV	DATE	SRN / SCN / ALTERATION	DRN	CHD	APPD

THIS DRAWING IS A SOLE PROPERTY OF SPIL & REVISION OR DUPLICATING IS AN OFFENCE

PART DESC.	PISTON ROD-M7				
-------------------	----------------------	--	--	--	--

THIRD ANGLE PROJECTION		SCALE	NTS	No. OFF PER ASSEMBLY	ASSEMBLE WITH	
NOMINAL TOLERANCE	ANGULAR TOL.	MATERIAL	C-35	1	SUB ASSY.PISTON ROD	
HEAT TREATMENT	MIN. 430Hv-0.1kg/15sec	DRN.	CKD.	APPD.	DATE	
HARDNESS	---	PRODUCT		PART NUMBER		
FINISH	N3	16-4 SERIES TOYOTA		S05184151		

SUSPA PNEUMATICS (I) LTD., CHENNAI.