

The print-out is not subject to the modification service.

Intended for internal and supplier use

Ident. Doc.: L21

Ⓐ piston rod processing per STAB-Spec. 10028999, table 1

RELEASE
for supplier
company Zhang Shi
05.10.2015 Schilz A.
(date / signature)

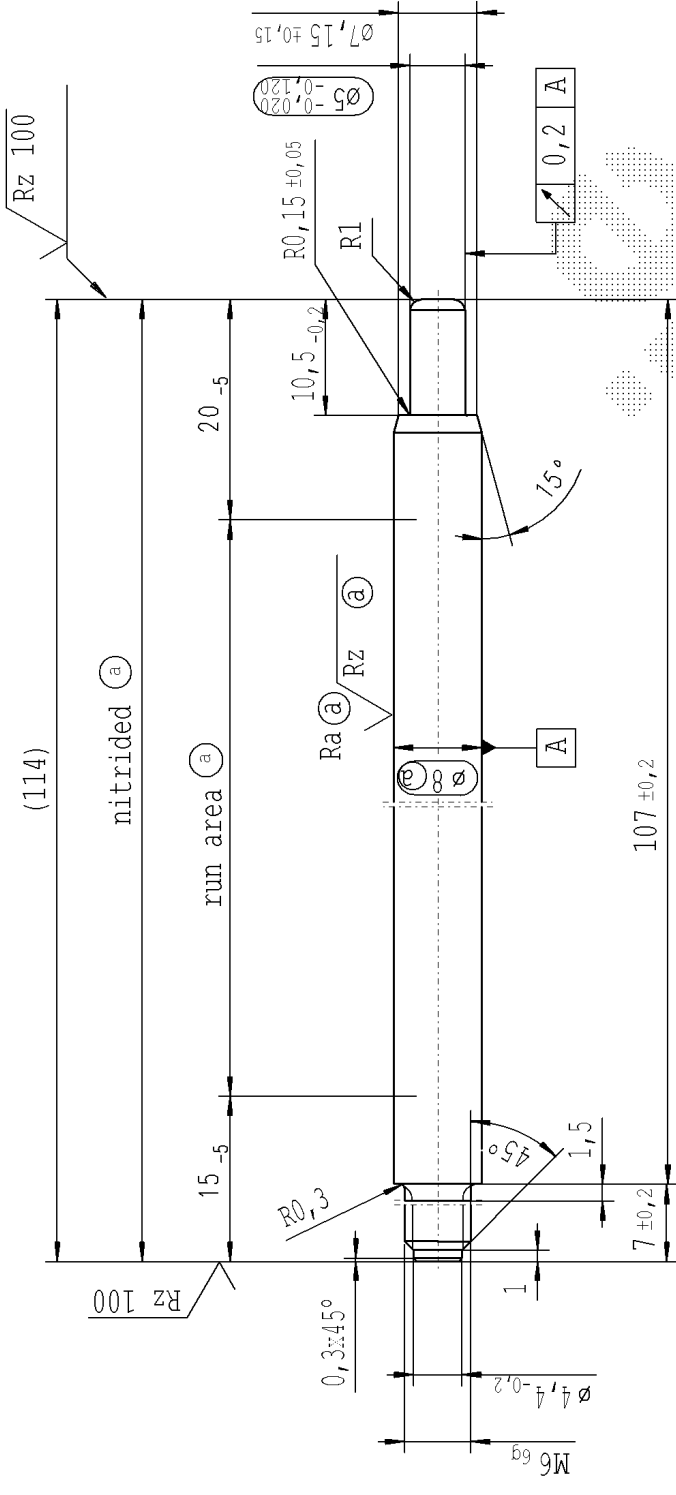

thread tolerances acc. to DIN ISO 965-3

√ Rz 25 (√ Rz 100 Ra Ⓐ Rz Ⓐ) | +0,2 | -0,2

A		AIAG CQI-standards acc. to STAB-Spec. 10027692		Environmental protection acc. to STAB-Spec. 10005649	
DE: X	EN: X	ES: X	IT: PR	FR: RO	RO: RO
new	INITIAL RELEASE	-	-	-	-
old	-	-	-	-	-
Field	-	-	-	-	-
Date/Name	05.10.2015 Jablonski	CAD created document; handwritten changes not permitted			
Chg. No.	629104	Material:	1.1193	All dimensions are in mm	
Rev.	0	Surface finish acc. to:	45C JISG 4051	Identification of important characteristics	
		Replaces:	Surface finish acc. to DIN ISO 1302	Dimensions without tolerances	
			DIN EN ISO 1302	Scale: 2:1	
				(Original DIN A3)	
				DIN ISO 2768-mK	
				We reserve all rights to this document, to any patents or patent registrations related hereto, and to the duplication, retransmission by third parties and misc. use. Any use of this document is not permitted without the written consent of STABILUS.	
				Document No.:	10151863
				Material No.:	353505
				STABILUS	
				PISTON ROD	
				PLANT: MOB1 PRINTER: JANSATOR FIXED DAY: 06.10.999 DOK-NR.: 10151863	