

The print-out is not subject to the modification service.

Intended for internal and supplier use

EN

B

A

Ident. Doc.: L10

ⓐ piston rod processing per STAB-Spec. 10028959, table 1

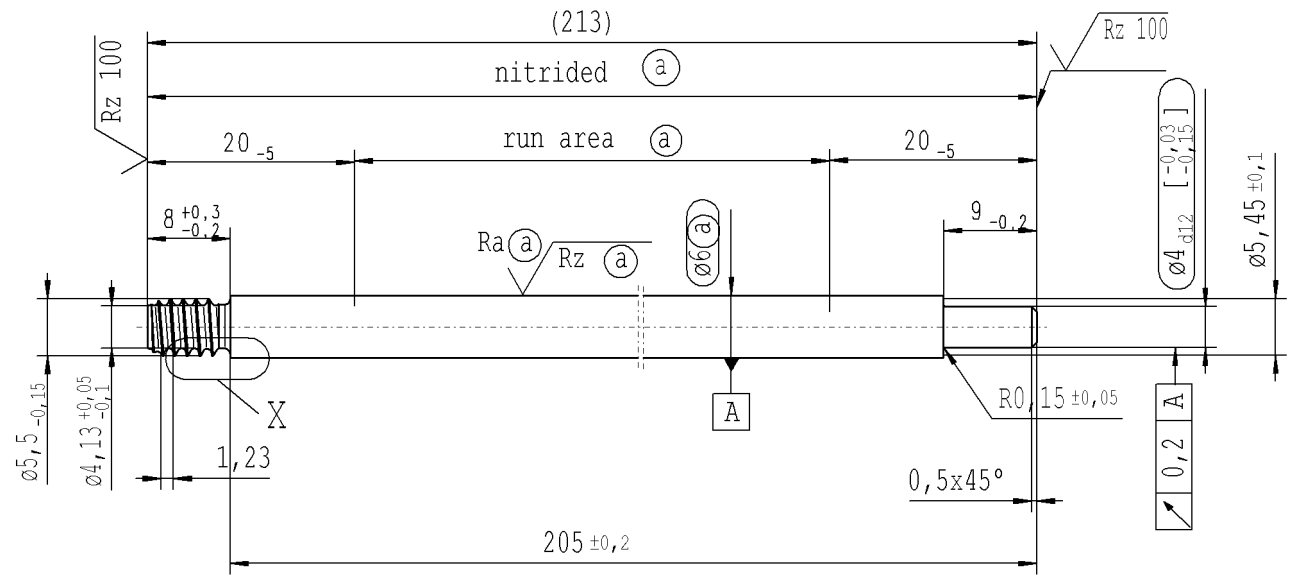

pre-worked:

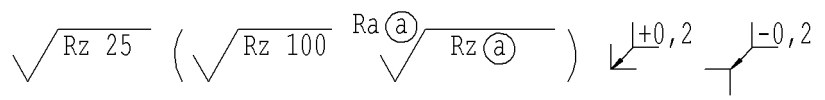
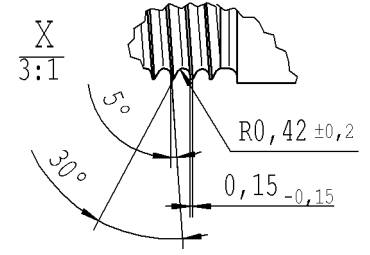
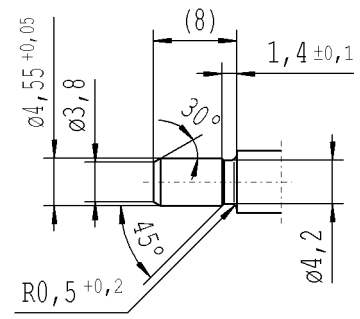

AIAG CQI-standards acc. to STAB-Spec. 10027692

Environmental protection acc. to STAB-Spec. 10005649

DE: X	EN: X	ES:	IT:	PR:	FR:	RO:	CRD created document; handwritten changes not permitted
new	INITIAL RELEASE						
old	-						
Field	-						
Date/Name	01.06.2018 Höfer						
Chg. No.	668945						
Rev.	0						

**RELEASE**  
for supplier

company ZhangShi

Dat. 04.06.2018 Schilz A.  
(date / signature)

Material: 1.1193  
S45C JISG 4051

Edge tolerances acc. to DIN ISO 13715

Surface finish DIN EN ISO 1302

Replaces:

**STABILUS**

All dimensions are in mm

Scale: (Original DIN A3) **2:1**

Identification of important characteristics

Dimensions without tolerances DIN ISO 2768-mK

We reserve all rights to this document, to any patents or patent registrations related hereto, and to the duplication, retransmission by third parties and misc. use. Any use of this document is not permitted without the written consent of STABILUS.

**PISTON ROD**

Drawn by	Date	Name
01.06.2018	Höfer	
Checked	Date	Milles
04.06.2018		
Document No.:	10177465	
Material No.:	952212	