

The print-out is not subject to the modification service.

Intended for internal and supplier use

EN

B

Ident. Doc.:

Ⓒ piston rod processing per STAB-Spec. 10028959, table 1

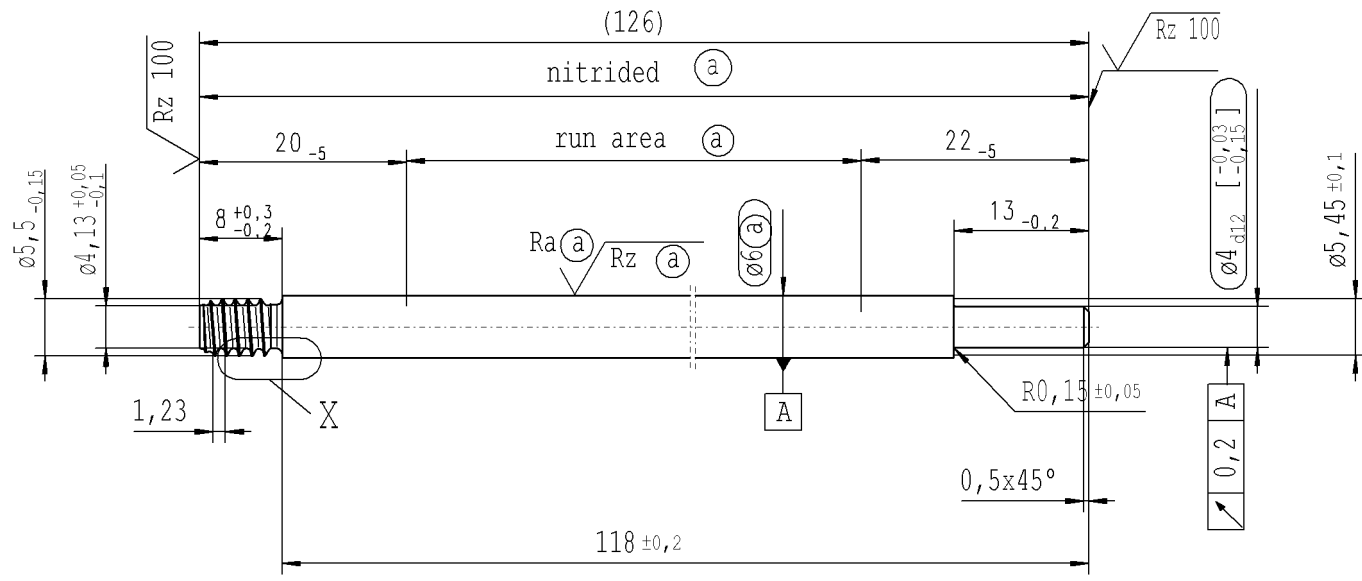

pre-worked:

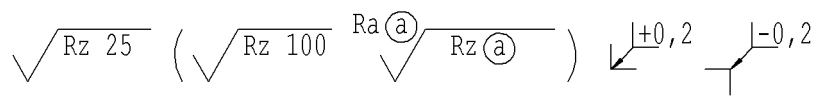
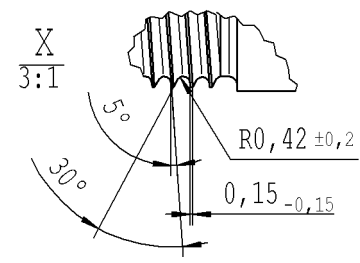
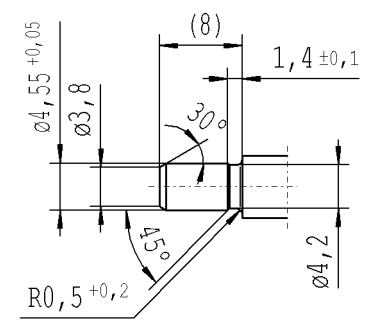

AIAG CQI-standards acc. to STAB-Spec. 10027692

Environmental protection acc. to STAB-Spec. 10005649

DE: X	EN: X	ES:	IT:	PR:	FR:	RO:	CRD created document; handwritten changes not permitted	
new	INITIAL RELEASE							
old	-							
Field	-							
Date/Name	05.11.2018 Höfer							
Chg. No.	673032							
Rev.	0							

RELEASE
for supplier

company Zhang Shi

Dat. 05.11.2018 Schilz A.
(date / signature)

Material: 1.1193
S45C JISG 4051

Edge tolerances acc. to DIN ISO 13715

Surface finish DIN EN ISO 1302

Replaces:

STABILUS

All dimensions are in mm

Scale: (Original DIN A3) **2:1**

Surface finish: Ra (a), Rz (a)

We reserve all rights to this document, to any patents or patent registrations related hereto, and to the duplication, retransmission by third parties and misc. use. Any use of this document is not permitted without the written consent of STABILUS.

PISTON ROD

Identification of important characteristics	Date	Name
Dimensions without tolerances DIN ISO 2768-mK	05.11.2018	Höfer
Document No.:	05.11.2018	Klinkner
Material No.:	10259201	
	468717	