

CONFIDENTIAL!
Intended for internal use only

supp No.	material no.			A	B	E
	surface treatment processing acc. STAB-Spec.			overall length	stud length end-fitting side	length without end-fitting stud
	10006248 Tab. IV	10006248 Tab. X	10028959 Tab. I China pay part			
1	228041	228041	228041	327	10	317
xx	xxxxxxx	xxxxxxx	xxxxxxx	303	9	294

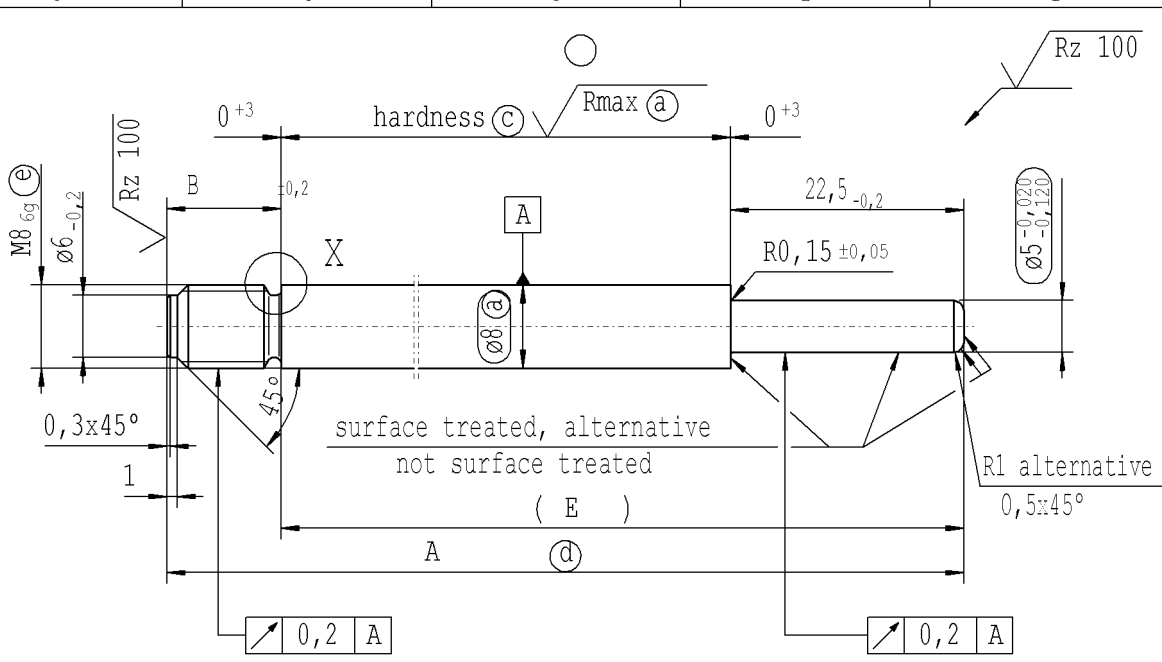

Production Stabilus

- (a) piston rod processing acc. to STAB-Spec. 10006248
- (c) RHT 0,4..0,7 mm before grinding, ≥ 68 HRA (acc. to DIN ISO 6508);
- (d) tolerances: $\begin{matrix} +0,2 \\ -0,1 \end{matrix}$ after turning; $\begin{matrix} +0,3 \\ -0,3 \end{matrix}$ after straightening; $\begin{matrix} +0,3 \\ -0,3 \end{matrix}$ after nisliding
- (e) threaded stud pre-turned dimension $\varnothing 7,14_{-0,06}$
thread roll tolerance 6e
thread tolerances acc. to DIN ISO 965-3

Zhang Shi
product family:
XXXX/xxxx
approved
lengths:
100-600 mm

Pay part China
acc separate
Supplier-
drawing

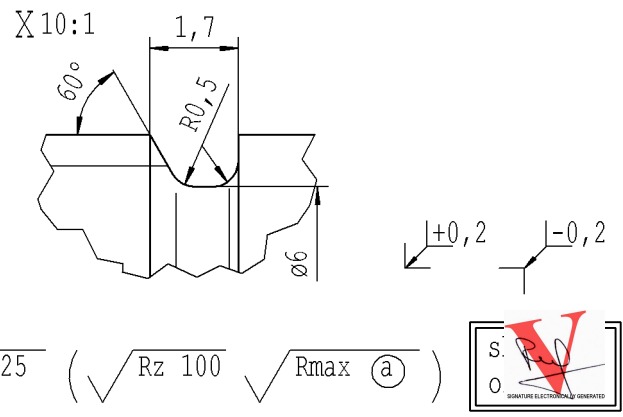

Environmental protection acc. to STAB-Spec. 10005649

Ident. Doc.: Error!Idem: 12/2/2018 - 13:21

DE: X	EN: X	ES:	IT:	PR:	FR:	RO:	CRD created document; handwritten changes not permitted	Material: mat.no. 010731	All dimensions are in mm	Identification of important characteristics	Drawn by 07.02.2018 Höfer	Date 07.02.2018	Name Höfer
new	INITIAL RELEASE							Edge tolerances acc. to DIN ISO 13715	Scale: (Original DIN A3) 2:1	Dimensions without tolerances DIN ISO 2768 mK	Checked 07.02.2018 Klinkner		
old	-							Surface finish DIN EN ISO 1302	We reserve all rights to this document, to any patents or patent registrations related hereto, and to the duplication, retransmission by third parties and misc. use. Any use of this document is not permitted without the written consent of STABILUS.				
Field	-							Replaces:	Document No.: 10252085				
Date/Name	07.02.2018 Höfer								Material No.:				
Chg. No.	-								Material No.:				
Rev.	0							STABILUS	PISTON ROD				