

CONFIDENTIAL!
Intended for internal use only

supp. No.	material no.			A	B	E	F
	surface treatment processing acc. STAB-Spec.			overall length	stud length end-fitting side	length without end-fitting stud	version
	10006248 Tab. IV	10006248 Tab. X	10028959 Tab. I China pay part				
1	006926		006926	237.0	10	227.0	1
2		702911	702911	243.0	10	233.0	1
3		704345	704345	276.0	10	266.0	1
4	913479	913479	913479	239.5	11	228.5	1
5	988771	988771	988771	267.0	9	258.0	1
6	853024	853024	853024	264.0	10	254.0	1
7	112126	112126	112126	276.0	9	267.0	1
8	115233	115233	115233	279.0	9	270.0	1
9	214896	214896	214896	285.0	9	276.0	1
10	218959	218959	218959	252.0	10	242.0	1
11	219915	219915	219915	270.0	10	260.0	1
12	506956	506956	506956	264.0	9	255.0	1
XXX	XXXXXXXX	XXXXXXXX	XXXXXX	321	10	311	1

Production Stabilus

(a) piston rod processing acc. to STAB-Spec. 10006248

(c) RHT 0,4..0,7 mm before grinding, ≥ 68 HRA (acc. to DIN ISO 6508);

(d) tolerances: $\begin{matrix} +0,2 \\ -0,1 \end{matrix}$ after turning; $\pm 0,3$ after straightening; $\pm 0,3$ after nisliding

(e) threaded stud pre-turned dimension $\varnothing 7,14_{-0,06}$
thread roll tolerance 6e
thread tolerances acc. to DIN ISO 965-3

for pay part China product family: 2008/0034
approved lengths: 100-600 mm

Pay part China acc separate Supplier-drawing

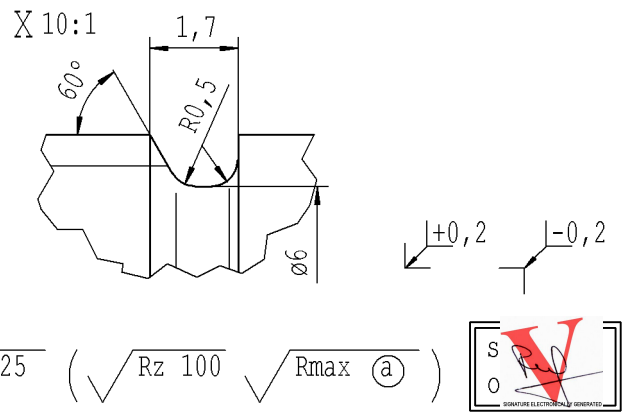
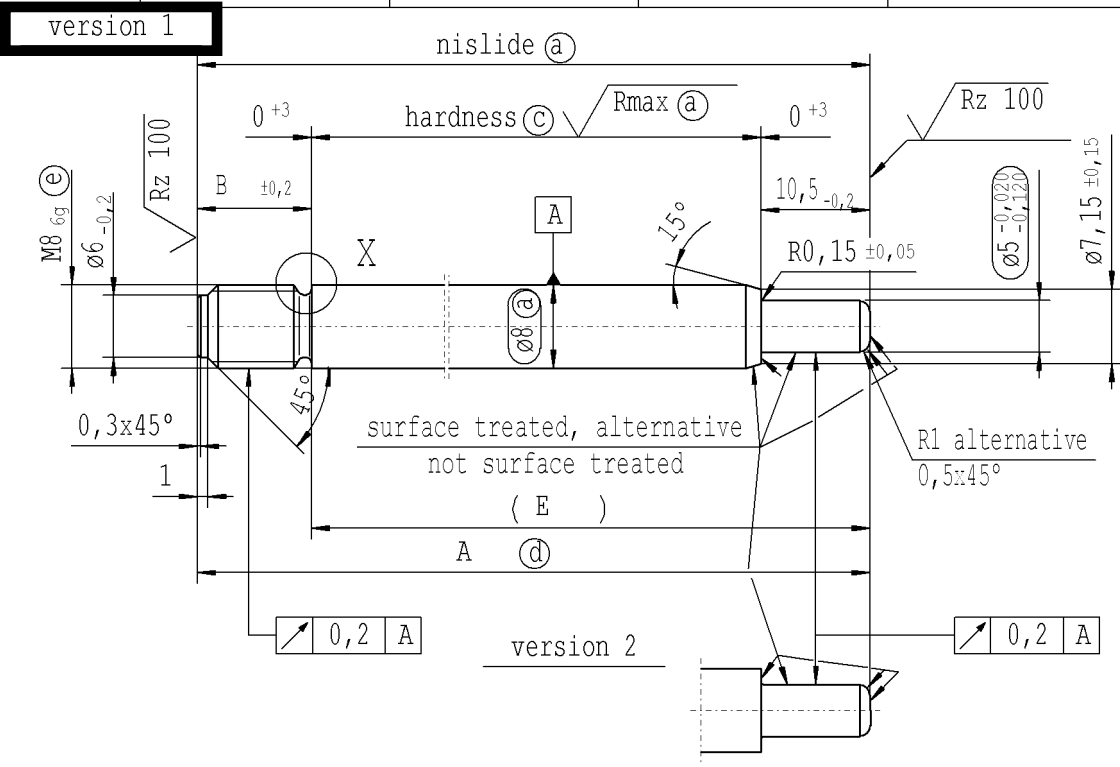

Ident. Doc.:
Erre11.docum: 10/7/2018 - 8:56

DE: X	EN: X	ES:	IT:	PR:	FR:	RO:	CAD created document; handwritten changes not permitted		Material:	All dimensions are in mm	Identification of important characteristics	Drawn by	Date	Name
new	text: product family ...	R1 alternative 0,5x45°	column Tab.X	column B	approved lengths: 100-600mm			mat.no. 010731	Scale: (Original DIN A3) 2:1	Dimensions without tolerances DIN ISO 2768 mK	Checked	17.01.2008	Höfer	
old	-; dimension B+dimension C	0,5x45°	-	-	approved lengths: 100-400mm			Edge tolerances acc. to DIN ISO 13715	We reserve all rights to this document, to any patents or patent registrations related hereto, and to the duplication, retransmission by third parties and misc. use. Any use of this document is not permitted without the written consent of STABILUS.					
Field	C/D5/6; A-F/7/8	E/1	A-F/7-8	A-F/6	B/6			Surface finish DIN EN ISO 1302	Document No.: 10152007					
Date/Name	15.04.2008 Hein	30.04.2009 Hein	30.07.2010 Höfer	10.03.2015 Höfer	24.11.2015 Hein			Replaces:	Material No.:					
Chg. No.	564472	572540	581955	622053	630576			STABILUS	PISTON ROD					
Rev.	1	2	3	4	5									