

The print-out is not subject to the modification service.

Intended for internal and supplier use

EN

Ident. Doc.: L001

ⓐ piston rod processing per STAB-Spec. 10028959, table 1

X 5:1

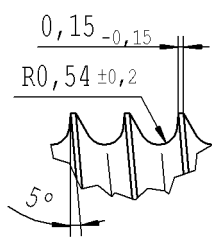

pre-worked:

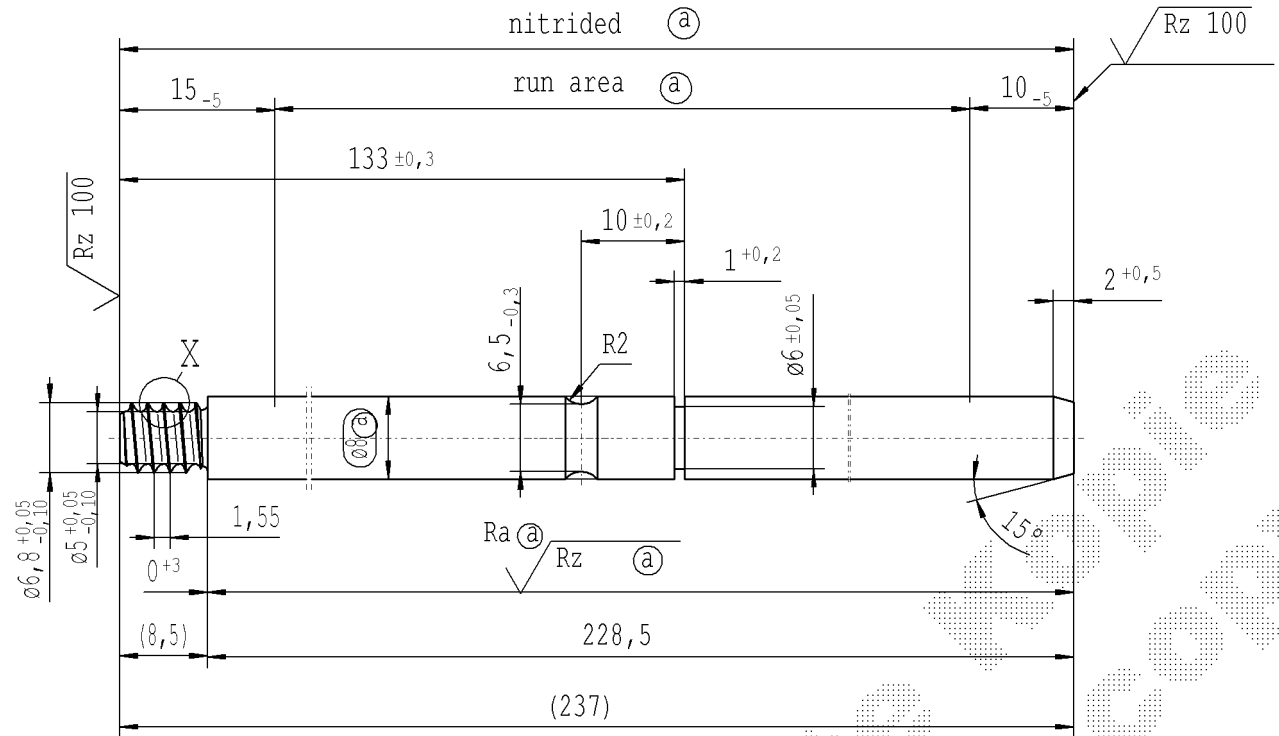
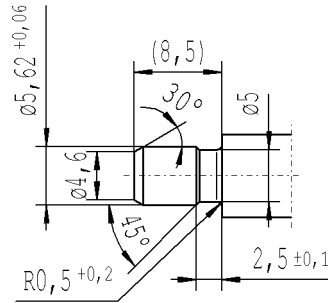

√ Rz 25 (√ Rz 100 Ra ⓐ Rz ⓐ) ↗ +0,2 ↘ -0,2

AIAG CQI-standards acc. to STAB-Spec. 10027692

Environmental protection acc. to STAB-Spec. 10005649

DE: X	EN: X	ES:	IT:	PR:	FR:	RO:
new	INITIAL RELEASE			237	228,5	133
old	-			235	226,5	-
Field	-			C4	D4	E5 E4
Date/Name	23.08.2018 Höfer			05.12.2018 Höfer		
Chg. No.	-			-		
Rev.	0			1		

CRD created document; handwritten changes not permitted

RELEASE
for supplier

company **Zhang Shi**

Dat. 05.12.2018 Schilz A.
(date / signature)

Material: 1.1193
S45C JISG 4051

Edge tolerances acc. to DIN ISO 13715

Surface finish: DIN EN ISO 1302

Registries:

STABILUS

All dimensions are in mm

Scale: (Original DIN A3) **2:1**

Identification of important characteristics

Dimensions without tolerances DIN ISO 2768-mK

We reserve all rights to this document, to any patents or patent registrations related hereto, and to the duplication, retransmission by third parties and misc. use. Any use of this document is not permitted without the written consent of STABILUS.

PISTON ROD

Drawn by	Date	Name
Checked		
Document No.:	23.08.2018	Höfer
	05.12.2018	Biris
Material No.:	10249121	
	606615	