

Ident. Doc.: L34

Intended for internal and supplier use

The print-out is not subject to the modification service.

ⓐ piston rod processing per STAB-Spec. 10028959, table 1

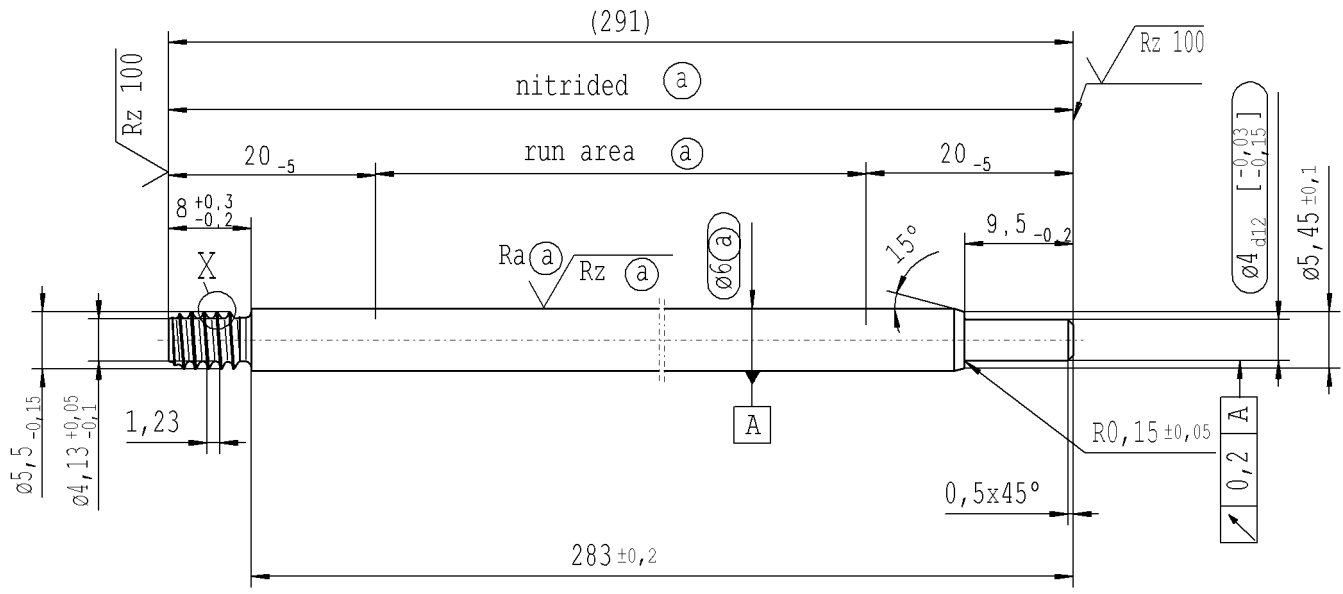

pre-worked:

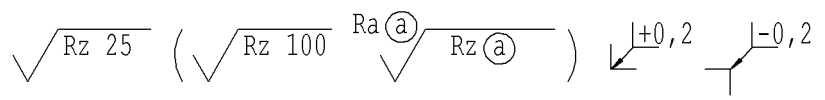
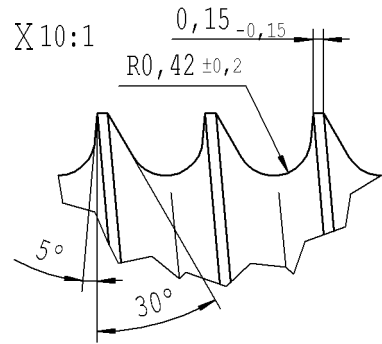
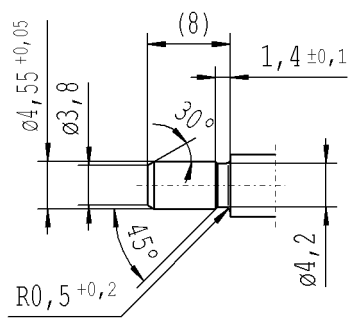

AIAG CQI-standards acc. to STAB-Spec. 10027692

Environmental protection acc. to STAB-Spec. 10005649

DE: X	EN: X	ES:	IT:	PR:	FR:	RO:	CRD created document; handwritten changes not permitted
new	INITIAL RELEASE						
old	-						
Field	-						
Date/Name	28.05.2019 Höfer						
Chg. No.	678682						
Rev.	0						

RELEASE
for supplier

company Zhang Shi

Dat. 28.05.2019 Schilz A.
(date / signature)

Material: 1.1193
S45C JISG 4051

Edge tolerances acc. to DIN ISO 13715

Surface finish DIN EN ISO 1302

Replaces:

STABILUS

All dimensions are in mm

Scale: (Original DIN A3) **2:1**

Identification of important characteristics

Dimensions without tolerances DIN ISO 2768-mK

We reserve all rights to this document, to any patents or patent registrations related hereto, and to the duplication, retransmission by third parties and misc. use. Any use of this document is not permitted without the written consent of STABILUS.

PISTON ROD

Drawn by	Date	Name
Checked	28.05.2019	Höfer
	28.05.2019	Milles
Document No.:	10151336	
Material No.:	553086	