

The print-out is not subject to the modification service.

Intended for internal and supplier use

EN

B

Ident. Doc.: L07

ⓐ piston rod processing per STAB-Spec. 10028959, table 1

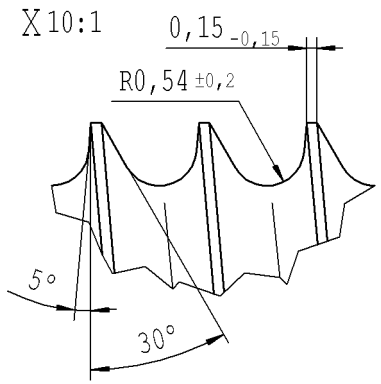
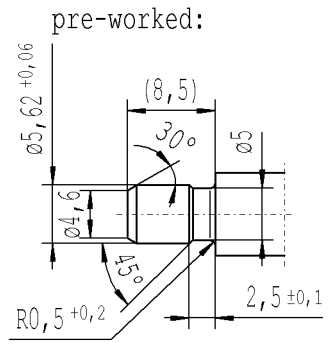
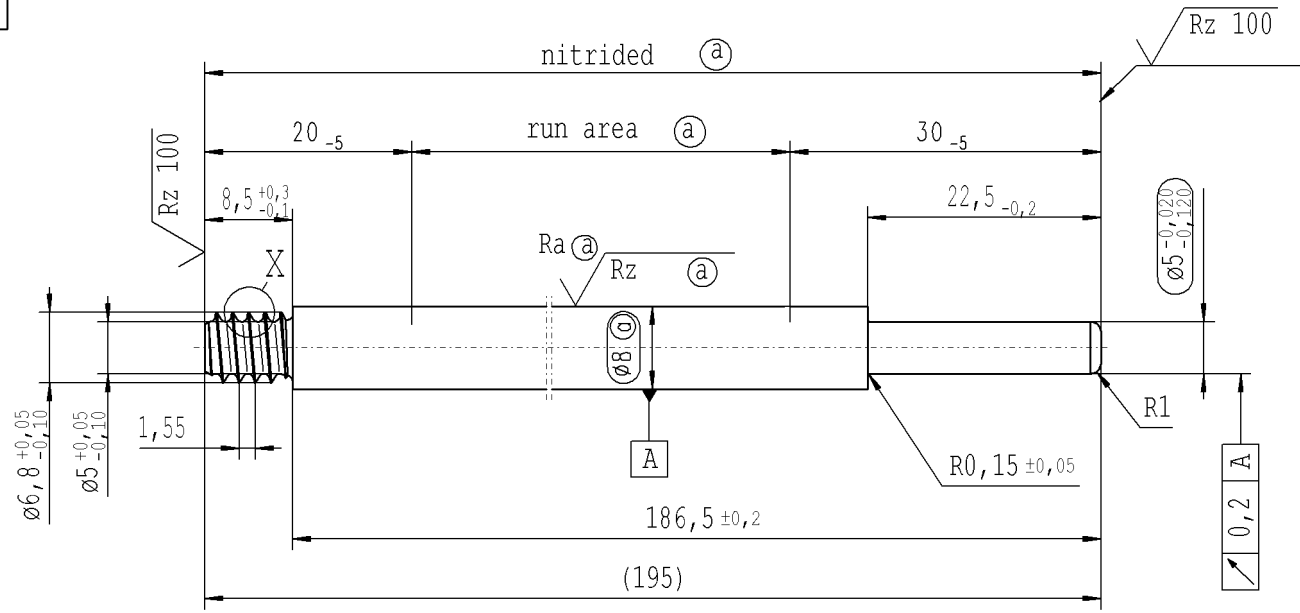

$\sqrt{Rz\ 25}$ ($\sqrt{Rz\ 100}$ $Ra\ \textcircled{a}$ $Rz\ \textcircled{a}$) $\begin{matrix} \swarrow +0,2 \\ \searrow -0,2 \end{matrix}$

AIAG CQI-standards acc. to STAB-Spec. 10027692

Environmental protection acc. to STAB-Spec. 10005649

DE: X	EN: X	ES:	IT:	PR:	FR:	RO:	CRD created document; handwritten changes not permitted
new	INITIAL RELEASE						
old	-						
Field	-						
Date/Name	05.09.2019 Höfer						
Chg. No.	681858						
Rev.	0						

RELEASE
 for supplier
 company Zhang Shi
 Dat. 05.09.2019 Schilz A.
 (date / signature)

Material: 1.1193
 S45C JISG 4051
 Edge tolerances acc. to DIN ISO 13715
 Surface finish DIN EN ISO 1302
 Replaces: **STABILUS**

All dimensions are in mm
 Scale: (Original DIN A3) **2:1**
 Identification of important characteristics
 Dimensions without tolerances DIN ISO 2768-mK
 We reserve all rights to this document, to any patents or patent registrations related hereto, and to the duplication, retransmission by third parties and misc. use. Any use of this document is not permitted without the written consent of STABILUS.

PISTON ROD

Drawn by	Date	Name
Checked	05.09.2019	Höfer
	05.09.2019	Milles
Document No.:	10154879	
Material No.:	430958	