

The print-out is not subject to the modification service.

Intended for internal and supplier use

Ident. Doc.: L281

ⓐ piston rod processing per STAB-Spec. 10028959, table 1

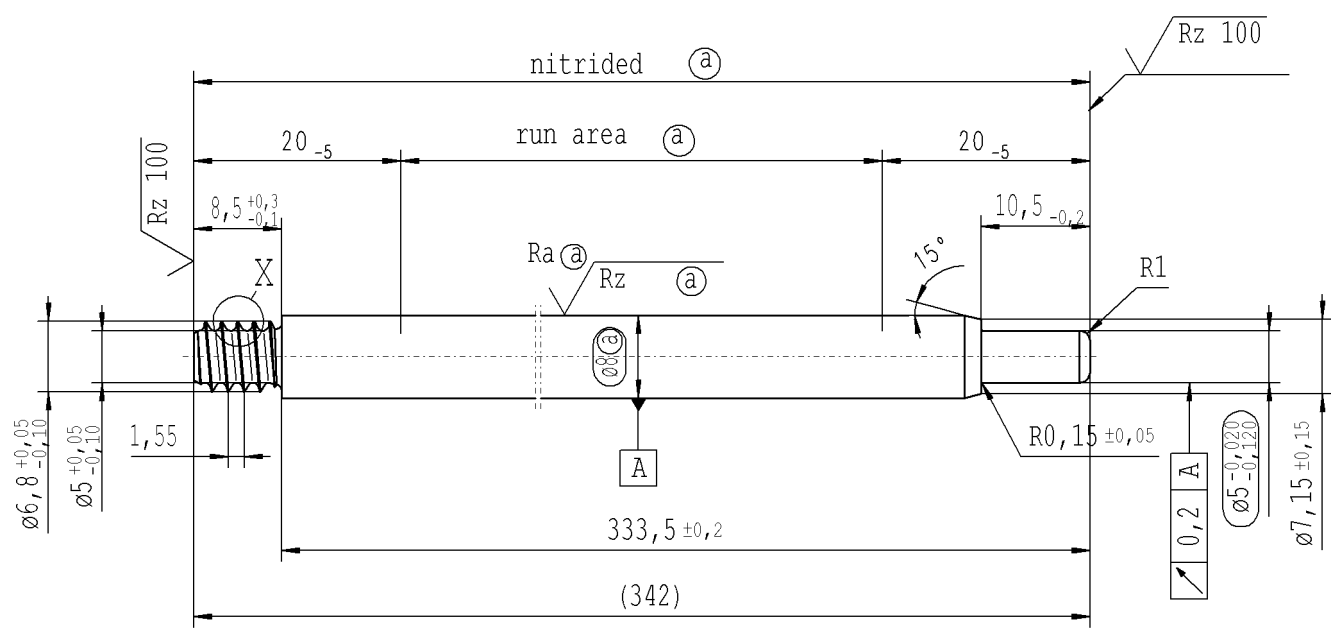

pre-worked:

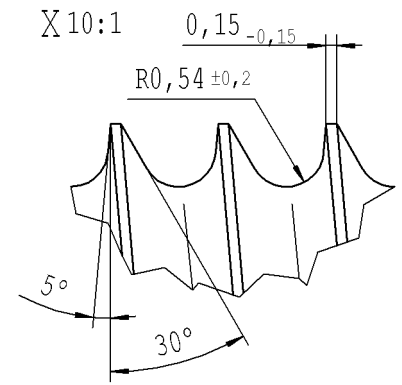
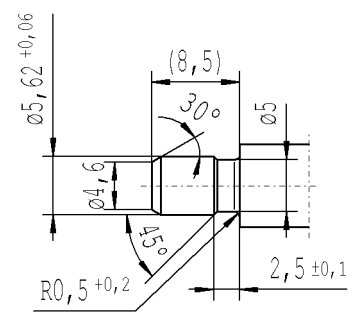

$\sqrt{Rz\ 25}$  ( $\sqrt{Rz\ 100}$   $Ra\ \textcircled{a}$   $Rz\ \textcircled{a}$ )  $\sqrt{+0,2}$   $\sqrt{-0,2}$

AIAG CQI-standards acc. to STAB-Spec. 10027692

Environmental protection acc. to STAB-Spec. 10005649

|           |                  |     |     |     |     |     |   |  |
|-----------|------------------|-----|-----|-----|-----|-----|---|--|
| DE: X     | EN: X            | ES: | IT: | PR: | FR: | RO: | CAD created document; handwritten changes not permitted |  |
| new       | INITIAL RELEASE  |     |     |     |     |     |   |  |
| old       | -                |     |     |     |     |     |   |  |
| Field     | -                |     |     |     |     |     |   |  |
| Date/Name | 01.10.2019 Höfer |     |     |     |     |     |   |  |
| Chg. No.  | 682796           |     |     |     |     |     |   |  |
| Rev.      | 0                |     |     |     |     |     |   |  |

**RELEASE**  
for supplier

company Zhang Shi

Dat. 01.10.2019 Schilz A.  
(date / signature)

Material: 1.1193  
S45C JISG 4051

Edge tolerances acc. to DIN ISO 13715

Surface finish DIN EN ISO 1302

Replaces:

**STABILUS**

All dimensions are in mm

Scale: (Original DIN A3) **2:1**

Identification of important characteristics

Dimensions without tolerances DIN ISO 2768-mK

We reserve all rights to this document, to any patents or patent registrations related hereto, and to the duplication, retransmission by third parties and misc. use. Any use of this document is not permitted without the written consent of STABILUS.

**PISTON ROD**

|               |            |        |
|---------------|------------|--------|
| Drawn by      | Date       | Name   |
| Checked       | 01.10.2019 | Höfer  |
| Document No.: |            | Milles |
| 10151065      |            |        |
| Material No.: |            |        |
| 658725        |            |        |