

The print-out is not subject to the modification service.

Intended for internal and supplier use

EN

Ⓐ piston rod processing per STAB-Spec. 10028959, table 1

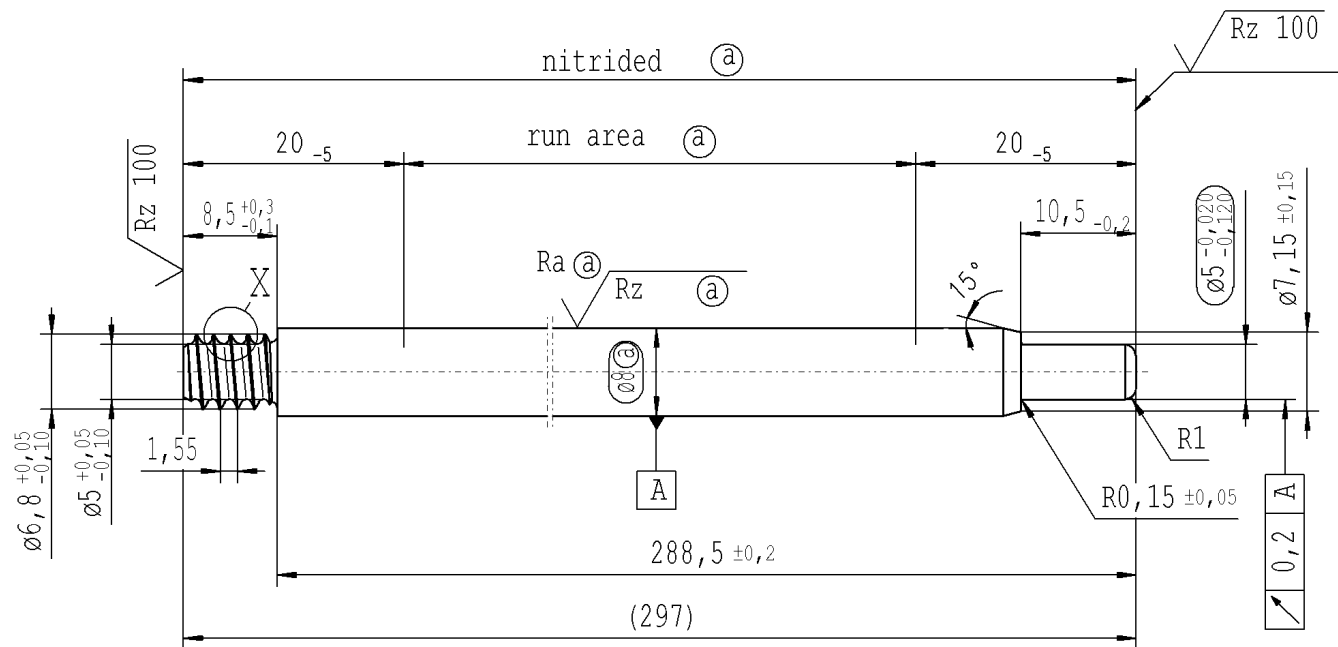

RELEASE
 for supplier
 company Zhang Shi
 14.07.2015 Schilz A.
 (date / signature)

pre-worked:

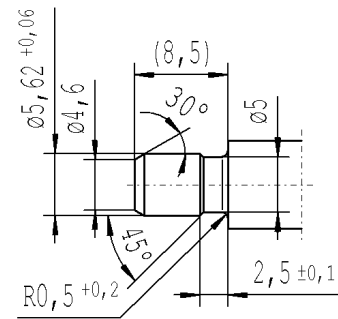

X 5:1

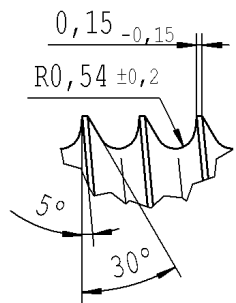

$\sqrt{Rz\ 25}$ ($\sqrt{Rz\ 100}$ $Ra\ \textcircled{A}$ $Rz\ \textcircled{A}$) $\swarrow +0,2$ $\searrow -0,2$

AIAG CQI-standards acc. to STAB-Spec. 10027692

Environmental protection acc. to STAB-Spec. 10005649

| | | | | | | |
|-----------|-----------------|-----------------|-----|-----|-----|-----------------|
| DE: X | EN: X | ES: | IT: | PR: | FR: | RO: |
| new | INITIAL RELEASE | run area | | | | R1 |
| old | - | hardness | | | | 0,5x45° |
| Field | - | F/4,5 | | | | E/2 |
| Date/Name | 21.05.2008 Hein | 02.08.2010, Bo. | | | | 13.07.2015 Hein |
| Chg. No. | - | 581802 | | | | 624057 |
| Rev. | 0 | 1 | | | | 2 |

| | |
|---|--------------------------|
| CAD created document; handwritten changes not permitted | |
| Material: | 1.1193 S45C JISG 4051 |
| Edge tolerances acc. to DIN ISO 13715 | |
| Surface finish | DIN EN ISO 1302 |
| Replaces: | |
| STABILUS | |

| | |
|--|---|
| All dimensions are in mm | Identification of important characteristics |
| Scale: (Original DIN A3) 2:1 | Dimensions without tolerances DIN ISO 2768-mK |
| We reserve all rights to this document, to any patents or patent registrations related hereto, and to the duplication, retransmission by third parties and misc. use. Any use of this document is not permitted without the written consent of STABILUS. | |
| PISTON ROD | |

| | | |
|---------------|----------|------|
| Drawn by | Date | Name |
| Checked | | |
| Document No.: | 10151065 | |
| Material No.: | 016174 | |

Ident. Doc.: L82