

The print-out is not subject to the modification service.

Intended for internal and supplier use

EN

Ⓐ piston rod processing per STAB-Spec. 10028959, table 1

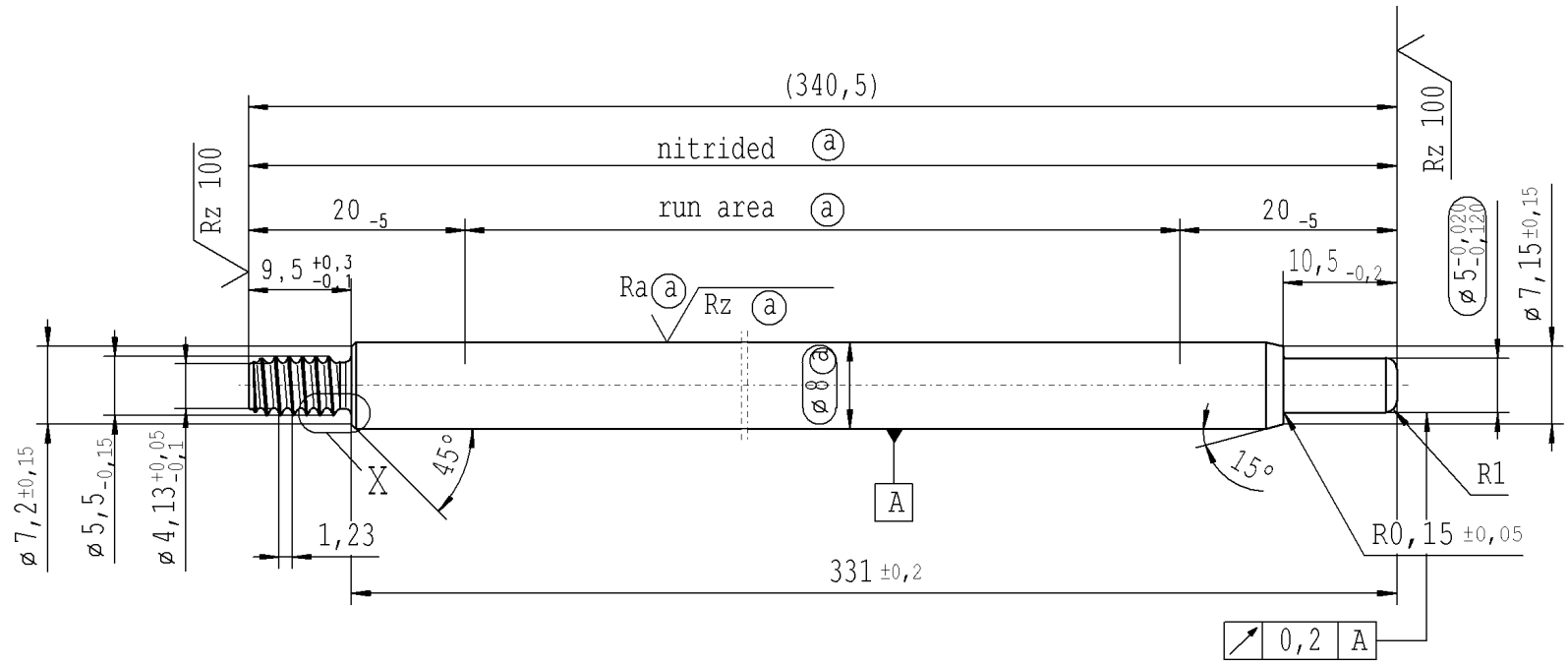

RELEASE
for supplier
company Zhang Shi
12.06.2015 Schilz A.
(date / signature)

pre-worked:

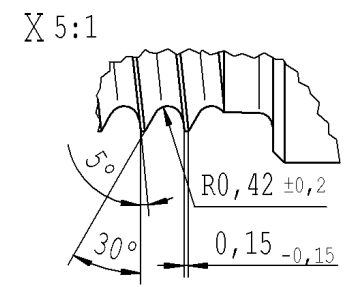
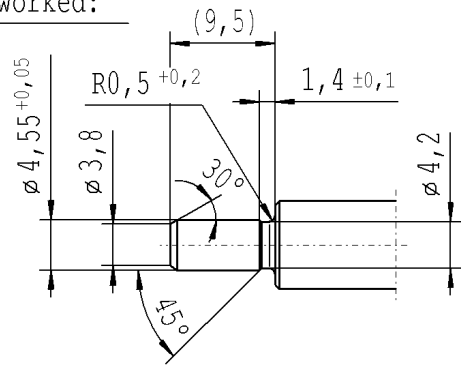

$\sqrt{Rz\ 25}$ ($\sqrt{Rz\ 100}$ $\sqrt{Ra\ (a)}$ $\sqrt{Rz\ (a)}$) $\begin{matrix} \swarrow +0,2 \\ \searrow -0,2 \end{matrix}$

AIAG CQI-standards acc. to STAB-Spec. 10027692

Environmental protection acc. to STAB-Spec. 10005649

Ident. Doc.: L77

DE: X	EN: X	ES:	IT:	PR:	FR:	RO:	CAD created document; handwritten changes not permitted
new	INITIAL RELEASE		R1				
old	-		0,5x45°				
Field	-		D-E/1-2				
Date/Name	29.10.2013 Kron		11.06.2015 Hein				
Chg. No.	607879		624058				
Rev.	0		1				

Material:	1.1193 S45C JISG 4051
Edge tolerances acc. to DIN ISO 13715	
Surface finish	DIN EN ISO 1302
Replaces:	
STABILUS	

All dimensions are in mm	Identification of important characteristics	Drawn by	Date	Name
Scale: (Original DIN A3) 2:1	Dimensions without tolerances DIN ISO 2768-mK	Checked	11.06.2015	Klinkner
We reserve all rights to this document, to any patents or patent registrations related hereto, and to the duplication, retransmission by third parties and misc. use. Any use of this document is not permitted without the written consent of STABILUS.		Document No.:	10151066	
		Material No.:	859698	
		PISTON ROD		

Material No.:	859698
---------------	--------