

The print-out is not subject to the modification service.

Intended for internal and supplier use

EN

Ⓐ piston rod processing per STAB-Spec. 10028959, table 1

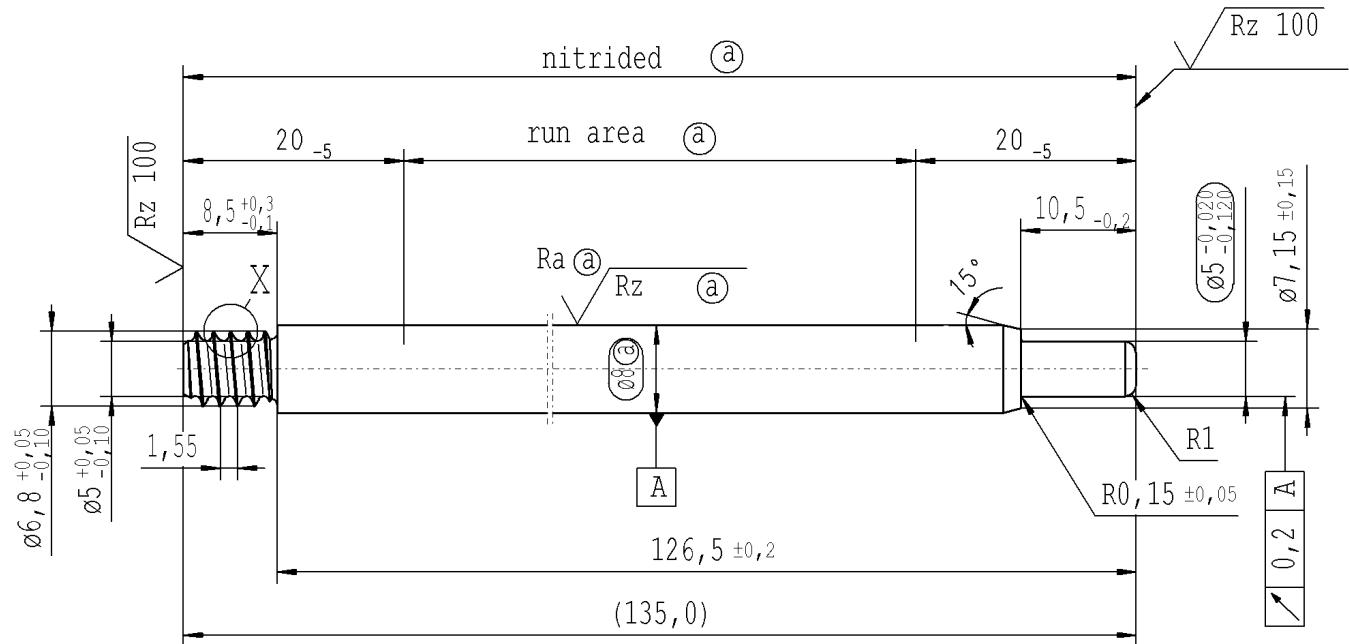

**RELEASE**  
for supplier  
company Zhang Shi  
14.07.2015 Schilz A.  
(date / signature)

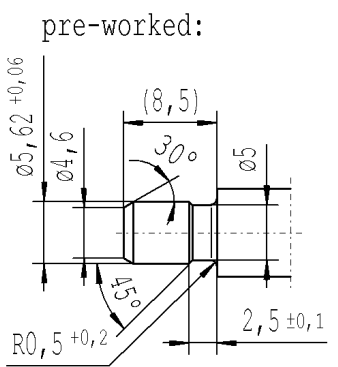

X 5:1

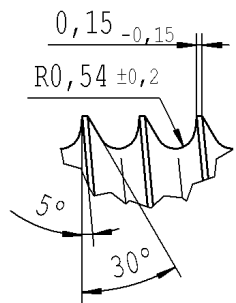

√ Rz 25 ( √ Rz 100 Ra Ⓐ Rz Ⓐ ) ↙ +0,2 ↘ -0,2

AIAG CQI-standards acc. to STAB-Spec. 10027692

Environmental protection acc. to STAB-Spec. 10005649

Ident. Doc.: L02

DE: X	EN: X	ES:	IT:	PR:	FR:	RO:	CAD created document; handwritten changes not permitted	
new	INITIAL RELEASE					run area	R1	
old	-					hardness	0,5x45°	
Field	-					F/4,5	E/2	
Date/Name	05.12.2007 Höfer				28.07.2010 Geisbusch	13.07.2015 Hein		
Chg. No.	-				581802	624057		
Rev.	0				2	3		

Material:	1.1193 S45C JISG 4051
Edge tolerances acc. to DIN ISO 13715	
Surface finish	DIN ISO 1302
Replaces:	
<b>STABILUS</b>	

All dimensions are in mm	Identification of important characteristics	Drawn by	Date	Name
Scale: (Original DIN A3) 2:1	Dimensions without tolerances DIN ISO 2768 mK	Checked	05.12.2007	Höfer
We reserve all rights to this document, to any patents or patent registrations related hereto, and to the duplication, retransmission by third parties and misc. use. Any use of this document is not permitted without the written consent of STABILUS.		Document No.: 10151065		
		Material No.: 008599		

Document No.: 10151065	
Material No.: 008599	