

The print-out is not subject to the modification service.

Intended for internal and supplier use

EN

Ident. Doc.: L165

Ⓐ piston rod processing per STAB-Spec. 10028959, table 1

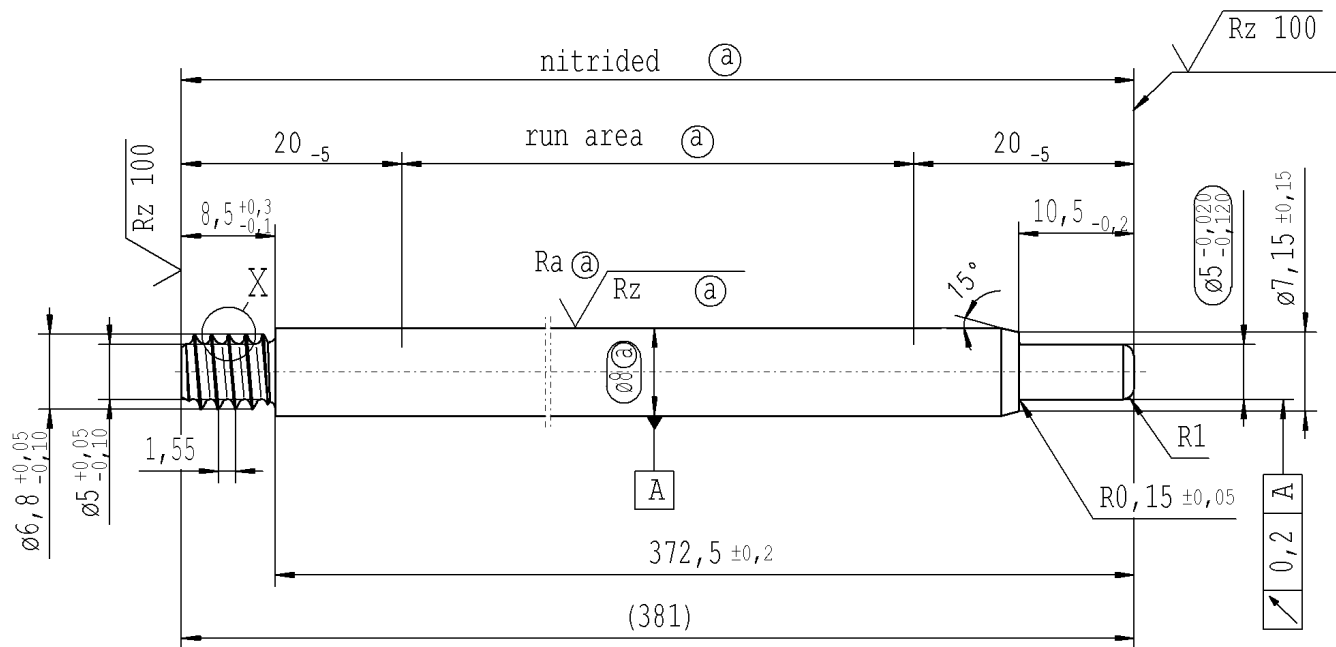

RELEASE
 for supplier
 company Zhang Shi
 16.07.2015 Schilz A.
 (date / signature)

pre-worked:

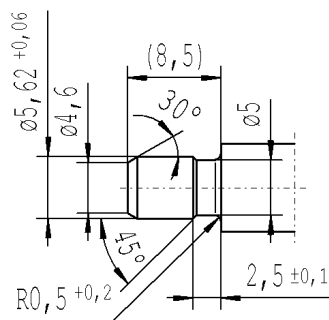

X 5:1

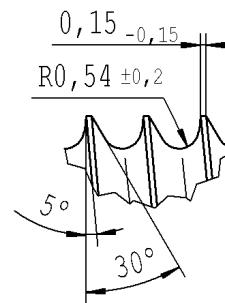

$\sqrt{Rz\ 25}$ ($\sqrt{Rz\ 100}$ $Ra\ \text{Ⓐ}$ $Rz\ \text{Ⓐ}$) $\swarrow +0,2$ $\searrow -0,2$

AIAG CQI-standards acc. to STAB-Spec. 10027692

Environmental protection acc. to STAB-Spec. 10005649

DE: X	EN: X	ES:	IT:	PR:	FR:	RO:	CAD created document; handwritten changes not permitted
new	372,5 ± 0,2		R1				
old	372,5		0,5x45°				
Field	D/4		E/2				
Date/Name	17.10.2012 Hein		15.07.2015 Hein				
Chg. No.	599668		624057				
Rev.	0		1				

Material:	1.1193 S45C JISG 4051
Edge tolerances acc. to DIN ISO 13715	
Surface finish	DIN EN ISO 1302
Replaces:	
STABILUS	

All dimensions are in mm	Identification of important characteristics
Scale: (Original DIN A3) 2:1	Dimensions without tolerances DIN ISO 2768-mK
We reserve all rights to this document, to any patents or patent registrations related hereto, and to the duplication, retransmission by third parties and misc. use. Any use of this document is not permitted without the written consent of STABILUS.	
PISTON ROD	

Drawn by	Date	Name
Checked	15.07.2015	Klinkner
Document No.: 10151065		
Material No.: 061669		