

The print-out is not subject to the modification service.

Intended for internal and supplier use

EN

Ⓐ piston rod processing per STAB-Spec. 10028959, table 1

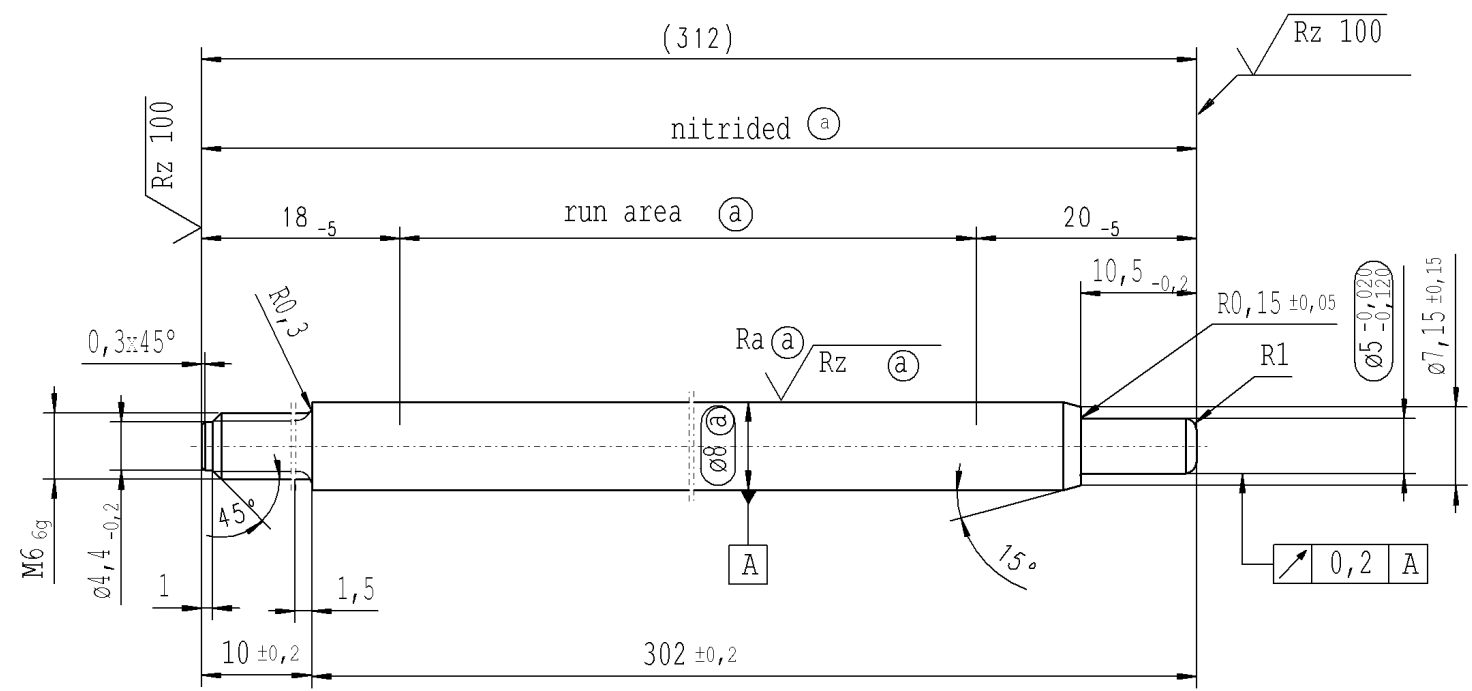

**RELEASE**  
 for supplier  
 company Zhang Shi  
 02.06.2015 Schilz A.  
 (date / signature)

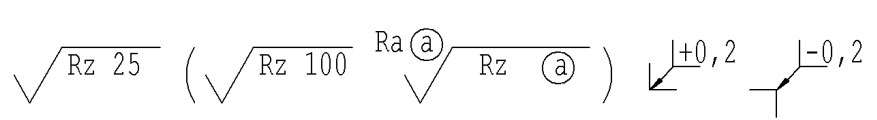

thread tolerances acc. to DIN ISO 965-3

AIAG CQI-standards acc. to STAB-Spec. 10027692

Environmental protection acc. to STAB-Spec. 10005649

Ident. Doc.: L09

DE: X	EN: X	ES:	IT:	PR:	FR:	RO:	CAD created document; handwritten changes not permitted
new	INITIAL RELEASE		R1				
old	-		0,5x45°				
Field	-		D-E/2				
Date/Name	30.03.2011 K.Marx		02.06.2015 Hein				
Chg. No.	587872		624061				
Rev.	0		1				

Material:	1.1193 S45C JISG 4051
Edge tolerances acc. to DIN ISO 13715	
Surface finish	DIN EN ISO 1302
Replaces:	
<b>STABILUS</b>	

All dimensions are in mm	Identification of important characteristics	Drawn by	Date	Name
Scale: (Original DIN A3) 2:1	Dimensions without tolerances DIN ISO 2768-mK	Checked	02.06.2015	Klinkner
We reserve all rights to this document, to any patents or patent registrations related hereto, and to the duplication, retransmission by third parties and misc. use. Any use of this document is not permitted without the written consent of STABILUS.		Document No.:		
		10154967		
		Material No.:		
		078876		

Document No.:		10154967	
Material No.:		078876	