

The print-out is not subject to the modification service.

Intended for internal and supplier use

EN

Ⓐ piston rod processing per STAB-Spec. 10028959, table 1

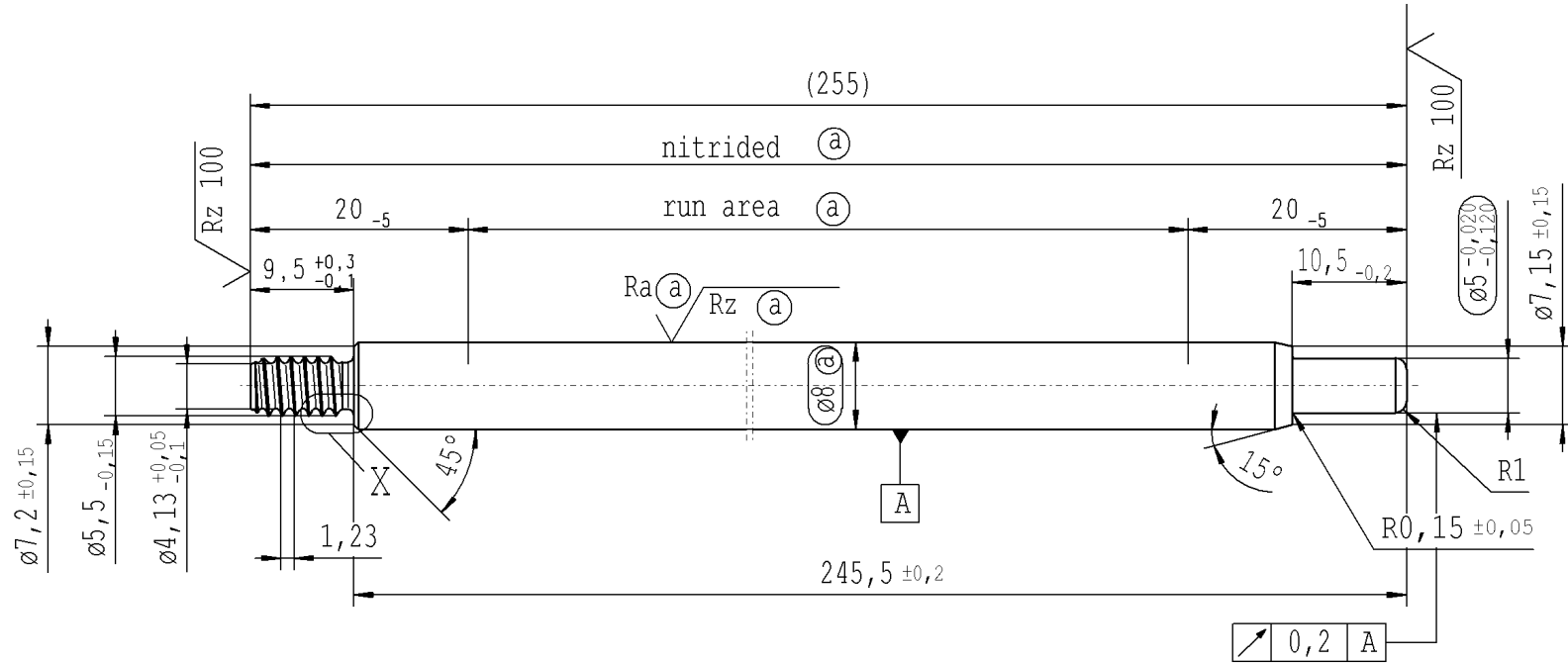

pre-worked:

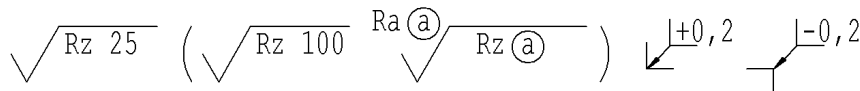
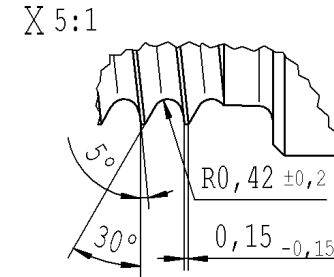
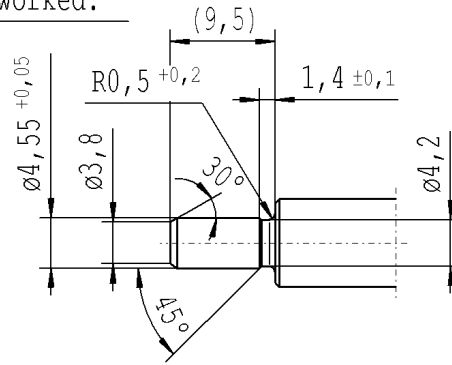

**RELEASE**  
for supplier  
company Zhang Shi  
12.06.2015 Schilz A.  
(date / signature)

AIAG CQI-standards acc. to STAB-Spec. 10027692

Environmental protection acc. to STAB-Spec. 10005649

Ident. Doc.: L19

DE: X	EN: X	ES:	IT:	PR:	FR:	RO:	CAD created document; handwritten changes not permitted	
new	INITIAL RELEASE		run area		R1			
old	-		hardness		0,5x45°			
Field	-		E 4/5		D-E/1-2			
Date/Name	03.03.2008 K.Marx		23.7.10 Keßelh.		11.06.2015 Hein			
Chg. No.	-		581803		624058			
Rev.	0		1		2			

Material:	1.1193 S45C JISG 4051
Edge tolerances acc. to DIN ISO 13715	
Surface finish	DIN EN ISO 1302
Replaces:	
<b>STABILUS</b>	

All dimensions are in mm	Identification of important characteristics	Drawn by	Date	Name
Scale: (Original DIN A3) 2:1	Dimensions without tolerances DIN ISO 2768-mK	Checked	11.06.2015	Klinkner
We reserve all rights to this document, to any patents or patent registrations related hereto, and to the duplication, retransmission by third parties and misc. use. Any use of this document is not permitted without the written consent of STABILUS.				
Document No.:			10151066	
Material No.:			005779	
<b>PISTON ROD</b>				

Date	Name
03.03.2008	K.Marx
11.06.2015	Klinkner
Document No.:	10151066
Material No.:	005779