

The print-out is not subject to the modification service.

Intended for internal and supplier use

EN

Ⓐ piston rod processing per STAB-Spec. 10028959, table 1

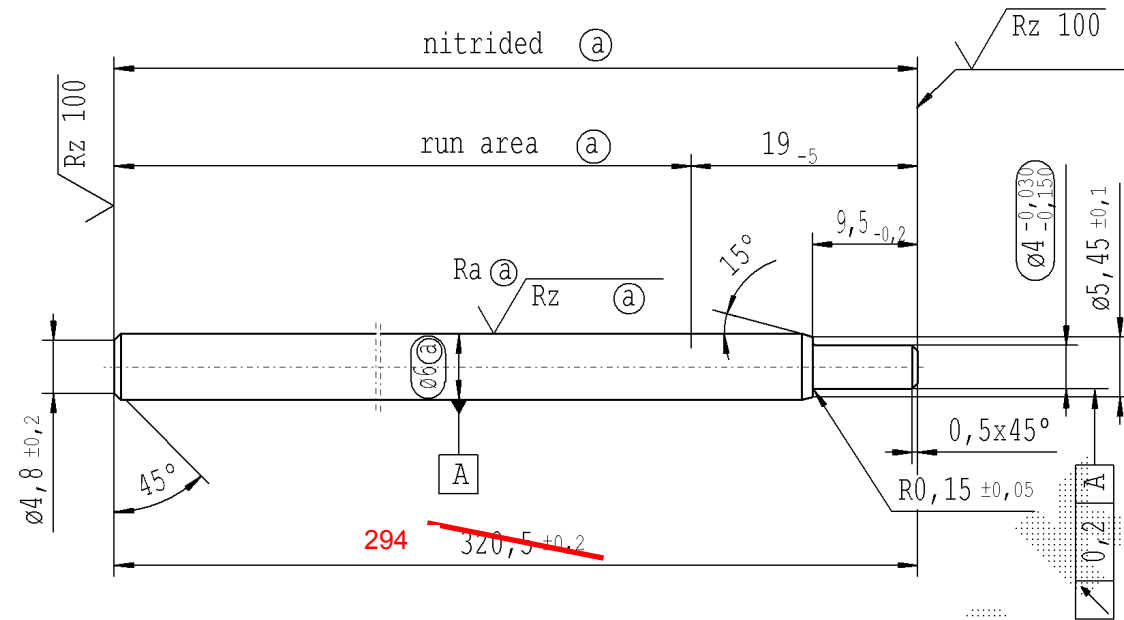

RELEASE
for supplier
company Zhang Shi

$\sqrt{Rz\ 25}$ ($\sqrt{Rz\ 100}$ Ra Ⓐ Rz Ⓐ) $\sqrt{+0,2}$ $\sqrt{-0,2}$

AIAG CQI-standards acc. to STAB-Spec. 10027892

Environmental protection acc. to STAB-Spec. 10005649

Ident. Doc.: I07

DE: X	EN: X	ES:	IT:	PR:	FR:	RO:
new	INITIAL RELEASE	19 _{,5}				
old	-	20 _{,5}				
Field	-	-				
Date/Name	14.03.2014 Hein	03.04.2014 Hein				
Chg. No.	-	-				
Rev.	0	1				

CAD created document; handwritten changes not permitted	
Material:	1.1193 S45C JISG 4051
Edge tolerances acc. to DIN ISO 13715	
Surface finish acc. to DIN EN ISO 1302	
Replaces:	
STABILUS	

All dimensions are in mm	Identification of important characteristics
Scale: (Original DIN A3) 2:1	Dimensions without tolerances DIN ISO 2768-mK
We reserve all rights to this document, to any patents or patent registrations related hereto, and to the duplication, retransmission by third parties and misc. use. Any use of this document is not permitted without the written consent of STABILUS.	

Drawn by	Date	Name
Checked	03.04.2014	Klinkner
Document No.: 10154979		
Material No.: -925186		