

The print-out is not subject to the modification service.

Intended for internal and supplier use

EN

Ident. Doc.: I24

Ⓐ piston rod processing per STAB-Spec. 10028959, table 1

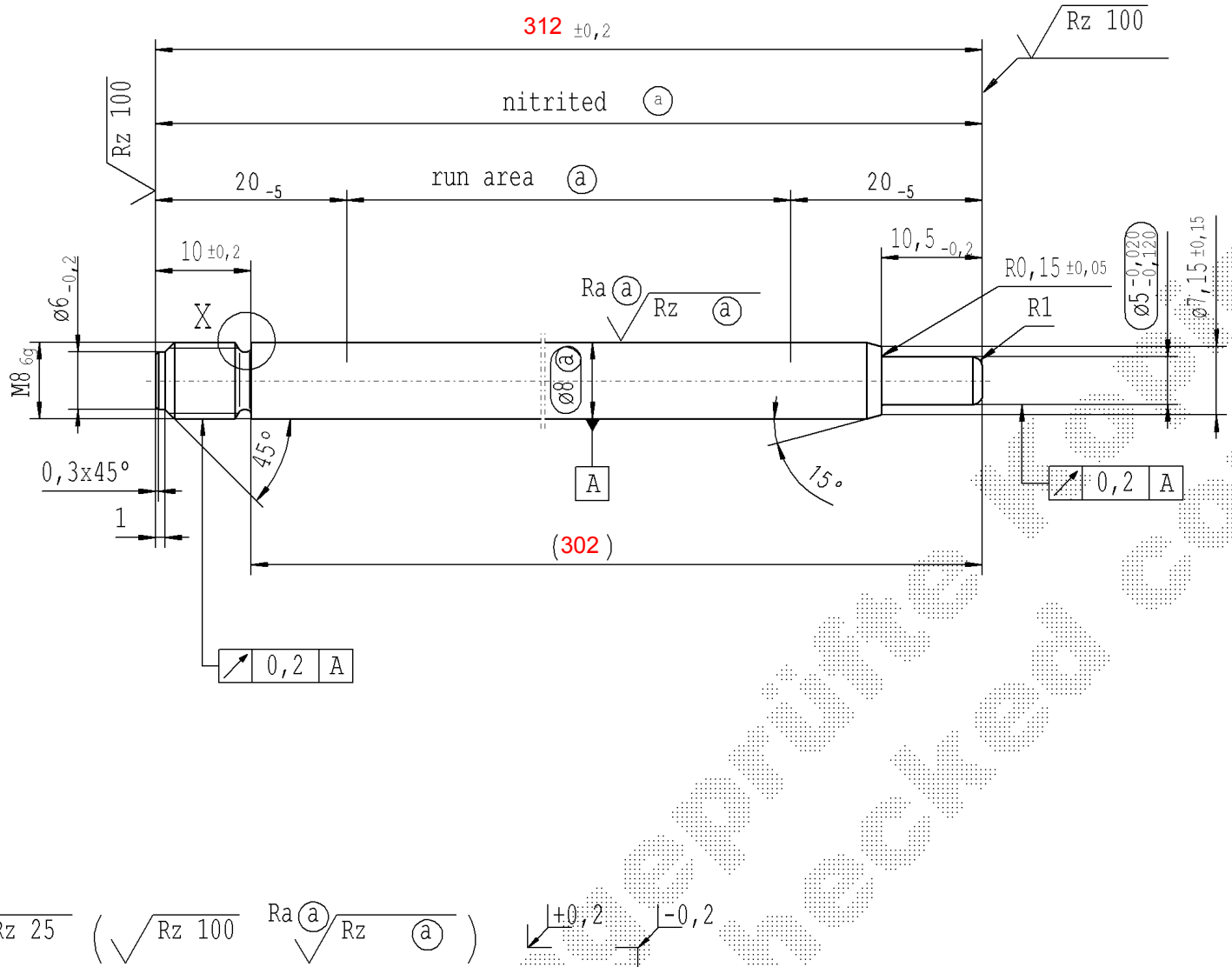

AIAG CQI-standards acc. to STAB-Spec. 10027892 Environmental protection acc. to STAB-Spec. 10005649

DE: X	EN: X	ES:	IT:	PR:	FR:	RO:
new	INITIAL RELEASE					
old	-					
Field	-					
Date/Name	18.12.2019 Höfer					
Chg. No.	684846					
Rev.	0					

CAD created document; handwritten changes not permitted

Material: 1.1193 S45C JISG 4051

Edge tolerances acc. to DIN ISO 13715

Surface Finish: DIN EN ISO 1302

Replaces:

STABILUS

RELEASE
for supplier

company Zhang Shi

Dat. 18.12.2019 Schilz A.
(date / signature)

All dimensions are in mm	Marking of special characteristics according to STAB-Spec. 10270932
Scale: (Original DIN A3) 2:1	Dimensions without tolerances DIN ISO 2768 mK
We reserve all rights to this document, to any patents or patent registrations related hereto, and to the duplication, retransmission by third parties and misc. use. Any use of this document is not permitted without the written consent of STABILUS.	

Drawn by	18.12.2019	Höfer
Checked	18.12.2019	Mauer
Document No.:	10152007	
Material No.:	PISTON ROD	