

The print-out is not subject to the modification service.

Intended for internal and supplier use

EN

Ident. Doc.: L001

Ⓒ piston rod processing per STAB-Spec. 10028959, table 1

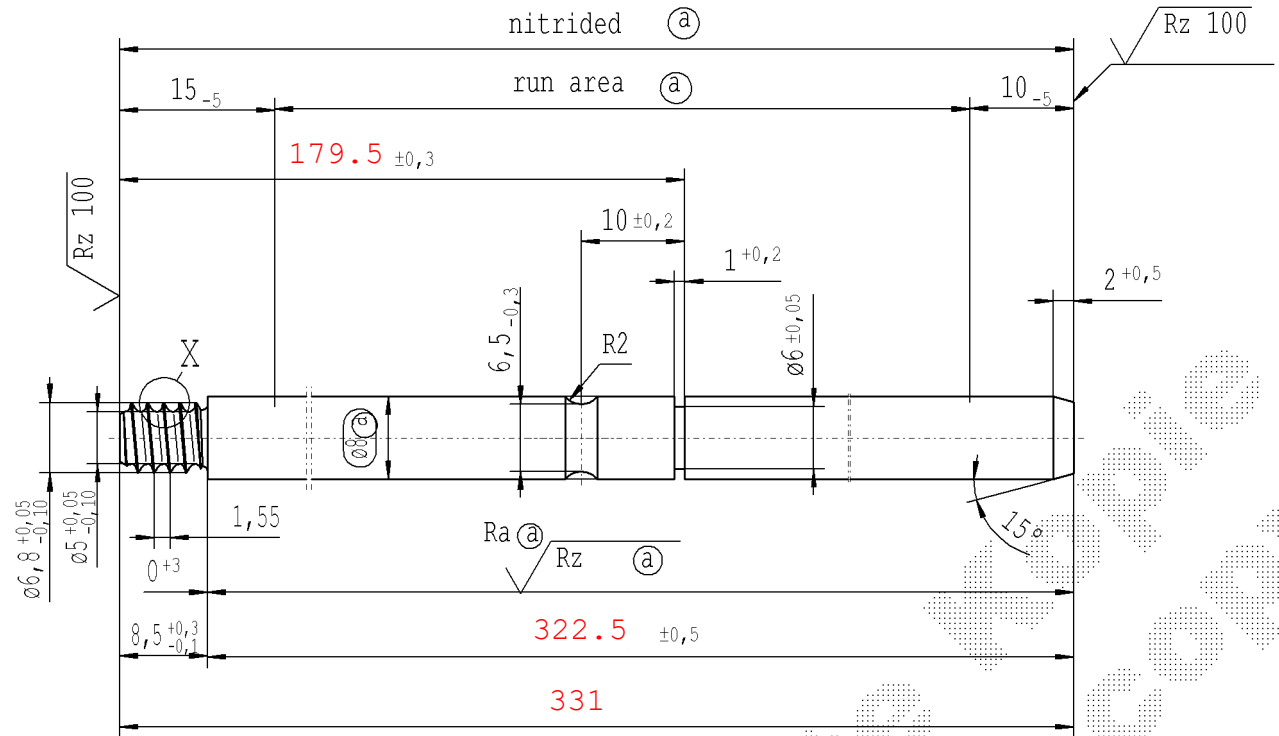
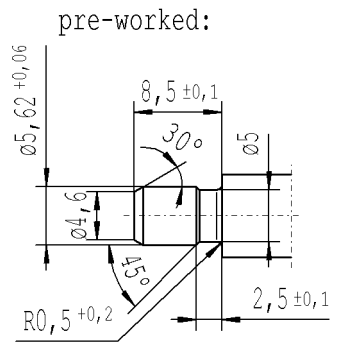
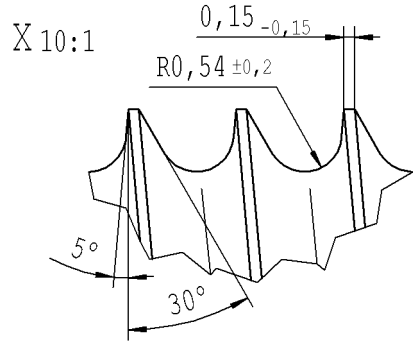

√ Rz 25 (√ Rz 100 Ra @ Rz @) ↗ +0,2 ↘ -0,2

AIAG CQI-standards acc. to STAB-Spec. 1002892

Environmental protection acc. to STAB-Spec. 10005649

DE: X	EN: X	ES:	IT:	PR:	FR:	RO:	CRD created document; handwritten changes not permitted
new	INITIAL RELEASE			237	228,5	133	10 132 ±0,3; 226,5 ±0,5; (235); 8,5 ±0,1; 8,5 ^{+0,3} / _{-0,1}
old	-			235	226,5	-	133 ±0,3; 228,5; (237); (8,5); (8,5)
Field	-			C4	D4	E5	E4 E-F/4-5; D/3-4; C/5-8
Date/Name	23.08.2018 Höfer			05.12.2018 Höfer			15.03.2019 Hein
Chg. No.	-			-			676120
Rev.	0			1			2

RELEASE
for supplier

company Zhang Shi

Dat. 15.03.2019 Schilz A.
(date / signature)

Material: 1.1193
S45C JISG 4051

Edge tolerances acc. to DIN ISO 13715

Surface finish: DIN EN ISO 1302

Registries:

STABILUS

All dimensions are in mm

Identification of important characteristics

Scale: (Original DIN A3) 2:1

Dimensions without tolerances DIN ISO 2768-mK

We reserve all rights to this document, to any patents or patent registrations related hereto, and to the duplication, retransmission by third parties and misc. use. Any use of this document is not permitted without the written consent of STABILUS.

Document No.: 10249121

Material No.: ~~606615~~

PISTON ROD

Drawn by	Date	Name
23.08.2018	Höfer	
Checked	Date	Name
15.03.2019	Lischetzki	

NEW