

Ident. Doc.: L56

③ piston rod processing per STAB-Spec. 10028959, table 1

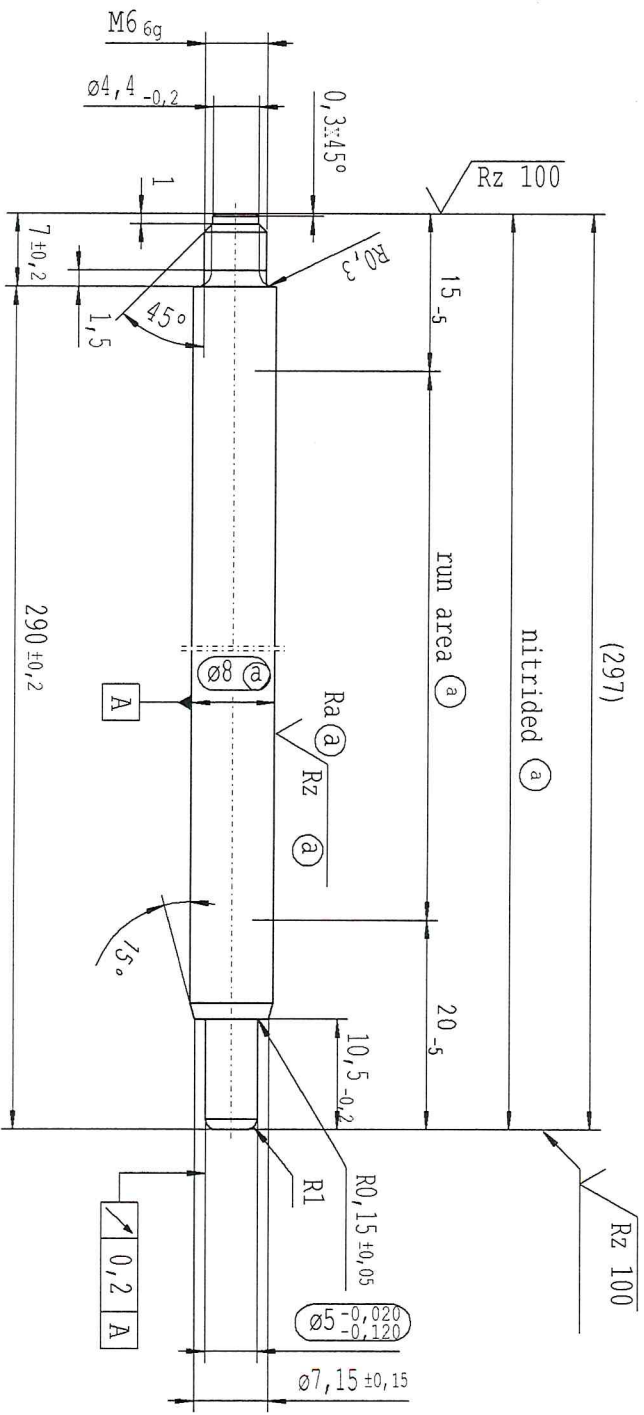

thread tolerances acc. to DIN ISO 965-3

ATAG CQI-standards acc. to STAB-Spec. 10021692 Environmental protection acc. to STAB-Spec. 10005649

DC: X	EN: X	ES:	IT:	PR:	FR:	RO:
new	INITIAL RELEASE					
old						
Date/Name	20.05.2020	Höfer				
Chg. No.	688543					
Rev.	0					

RELEASE for supplier
 company Zhang Shi
 Dat. 20.05.2020 PomIn H.
 (date / signature)

Material:	1.1193
S45C JISG 4051	
Edge tolerances acc. to DIN ISO 13715	
Surface finish DIN EN ISO 1302	
Replaces:	

All dimensions are in mm
 Scale: 2:1
 Marking of special characteristics according to STAB-Spec. 10270932
 Dimensions without tolerances DIN ISO 2768-mK
 No reserve all rights to this document, to any patents or patent applications, to any trademarks, to any other intellectual property rights by third parties and also, use. Any use of this document is not permitted without the written consent of STABILUS.

Document No.:	10151863
Material No.:	190050
Drawn by	20.05.2020 Höfer
Checked	20.05.2020 Müller

STABILUS PISTON ROD