

CONFIDENTIAL!  
Intended for internal use only

EN

supp. No.	material no.				A	B	E	F	G
	surface treatment processing acc. to STAB-Spec. 10006248	table IV Nislid black	table V Nislid light	table VIII Nislid black polished					
81	4702FY			4702FY	228.0	10.5	219.5	1	
82	4712FS			4702FY	168.0	10.5	159.5	1	
83	4718FP				357.0	10.5	348.5	1	
84	4766FW			4766FW	117.0	10.5	108.5	1	
85	4772FJ	0771RZ		4772FJ	192.0	10.5	183.5	1	
86	4775FV			4775FV	90.0	10.5	81.5	1	
87	4838FX				234.0	10.5	225.5	1	
88	4952FH			4952FH	120.0	10.5	111.5	1	
89	5175FB				261.0	16.5	252.5	2	
90	5182FK	9047NG			309.0	10.5	300.5	1	
91	5209FQ			5209FQ	402.0	10.5	393.5	1	
92	5388FU				348.0	10.5	339.5	1	
93	5504FU				229.5	10.5	221.0	1	
94	5559FT				198.0	10.5	189.5	1	
95	5586FQ				279.0	11.5	270.5	2	
96	5986FP		5641FE	5986FP	162.0	10.5	153.5	1	
97	5666FV				205.0	10.5	196.5	1	
98	5547FI				159.0	10.5	150.5	1	
99	5818FA			5818FA	174.0	10.5	165.5	1	
100	5826FE			5826FE	171.0	10.5	162.5	1	

(a) piston rod processing acc. to STAB-Spec. 10006248

(b) surface chrome-free

(c) RHT 0,4..0,7 mm before grinding, ≥ 68 HRA (acc. to DIN ISO 6508);

(d) tolerances:  $+0,2$  after turning;  
 $-0,1$  after straightening;  
 $+0,3$  after straightening;  
 $+0,3$  after nisliding

Temporary deviation approval: 031/02

Only apply to

STDE	STES	STGB	STIT	STAU	STUS	STMX	STBR	STNZ	STKR

**Caution!** For delivery to STKR:  
Surface treatment  
nislid only allowable acc. to tab. IV.  
Concerned piston rods, see column G

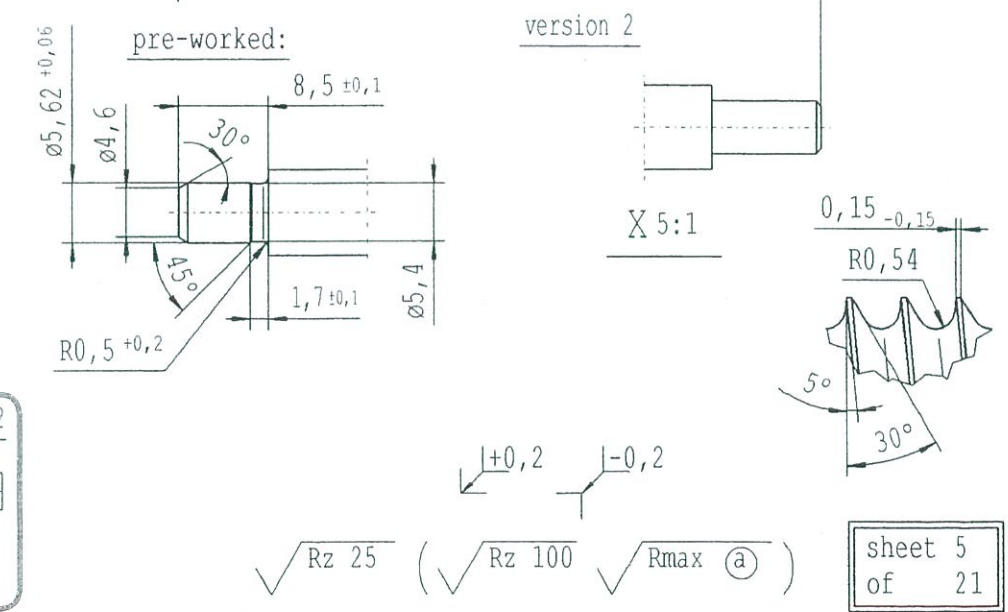
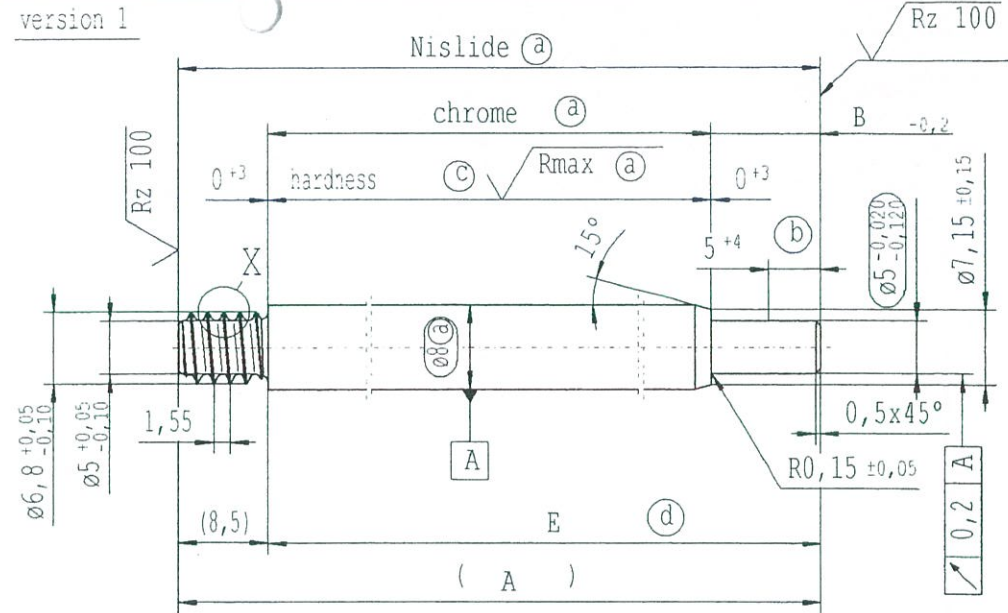

sheet 5  
of 21

Environmental protection acc. to STAB-Spec. 10005649

DE: X	EN: X	ES: X	IT: X	PR: X	FR:	CAD created document; handwritten changes not permitted														
new	design revised		TED 031/02		delete text: "For delivery to STKR:"	%	+	Tab. IV + X	Rework	"For delivery to STKR:"										
old	%	%	%		TED 031/02	%	031/02	STIT	div. Pos.	%	TED 031/02									
Field	%	%	%		TED 031/02	%	031/02	STIT	div. Pos.	%	TED 031/02									
Date/Name	03.07.2001 Jab.	06.12.2002 SuB	09.01.2003 SuB	06.02.2003 SuB	16.04.2003 Pulze	28.04.2003 Kannew.	31.07.2003 SuB	19.02.2004 SuB												
Chg. No.	514653	525173	525601	526440	528128	529220	530475	535263												
Rev.	46	47	48	49	50	51	52	53												

Material:  
mat.no. 010731

Edge tolerances acc. to DIN ISO 13715

Surface finish DIN ISO 1302

Replaces:  
Zchnng. gl. Nr. v. 17.12.1998

**STABILUS**

All dimensions are in mm

Scale: (Original DIN A3) 2:1

Identification of important characteristics

Dimensions without tolerances

DIN ISO 2768 mK

We reserve all rights to this document, to any patents or patent registrations related hereto, and to the duplication, retansmission by third parties and misc. use. Any use of this document is not permitted without the written consent of STABILUS.

Document No.:  
**10001245**

Material No.:

**PISTON ROD**

Date	Name
08.11.1999	Mohrs
19.02.2004	Rüdesch.

ZALIS

Ident. Doc.: SN 266345