

The print-out is not subject to the modification service.

Intended for internal and supplier use

EN

Ident. Doc.:

Date: 5/9/2020 - 11:47

supp No.	material no.			A overall length	B thread length	E length without end-fitting stud
	processing and surface treatment acc. to STAB-Spec.					
	10006248 Tab. IV (a) version 1	10006248 Tab. X (a) version 1	10028959 Tab. I (b) version 2			
1		004968	004968	118.5	7	111.5
2		006834	006834	108.0	7	101.0
3		014584	014584	317.5	7	310.5
4	562855	562855	562855	138.0	7	131.0
5		521987	521987	150.0	7	143.0
6	709841	709841	709841	165.0	7	158.0
7	357078	357078	357078	93.0	7	86.0
8	585087	585087	585087	123.0	7	116.0
9	528206	528206	528206	207.0	7	200.0
10	641015	641015	641015	102.0	7	95.0
11	353740	353740	353740	180.0	7	173.0
12	782506	782506	782506	129.0	7	122.0
13	791588	791588	791588	111.0	7	104.0
14	798280	798280	798280	174.0	7	167.0
15	999279	999279	999279	222.0	7	215.0
16	041129	041129	041129	225.0	7	218.0
17	933794	933794	933794	210.0	7	203.0
18	035872	035872	035872	135.0	7	128.0
19	107333	107333	107333	231.0	7	224.0
20	348725	348725	348725	126.0	7	119.0
21	353505	353505	353505	114.0	7	107.0
22	438590	438590	438590	300.0	7	293.0
23	449345	449345	449345	501.0	7	494.0
24	364739	364739	364739	219.0	7	212.0
25	372626	372626	372626	144.0	7	137.0
26	375494	375494	375494	273.0	7	266.0
27	208912	208912	208912	213.0	7	206.0
28	218711	218711	218711	186.0	7	179.0
29	219906	219906	219906	249.0	7	242.0

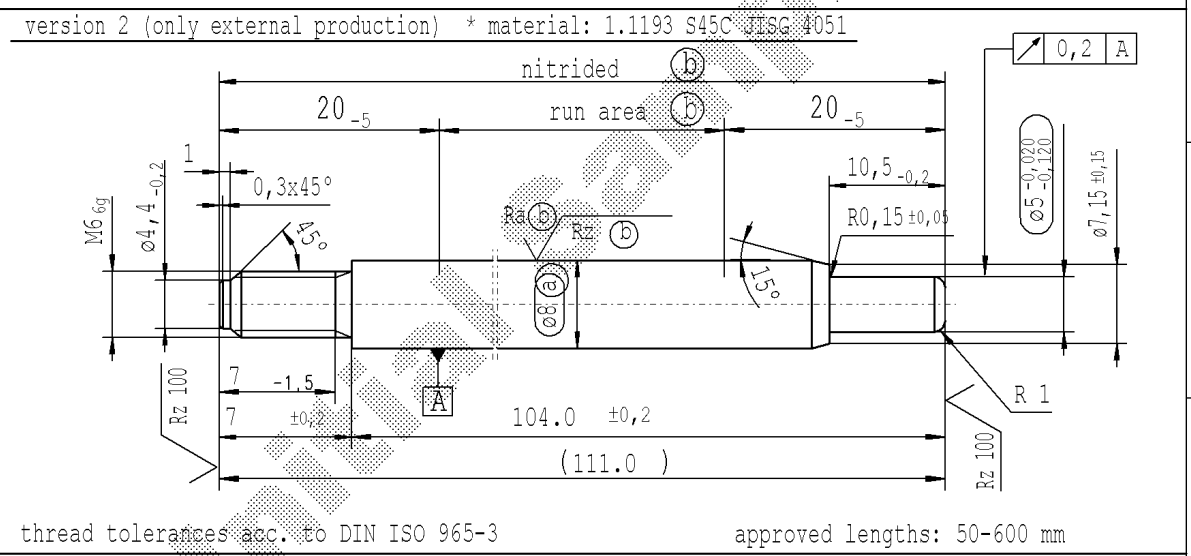
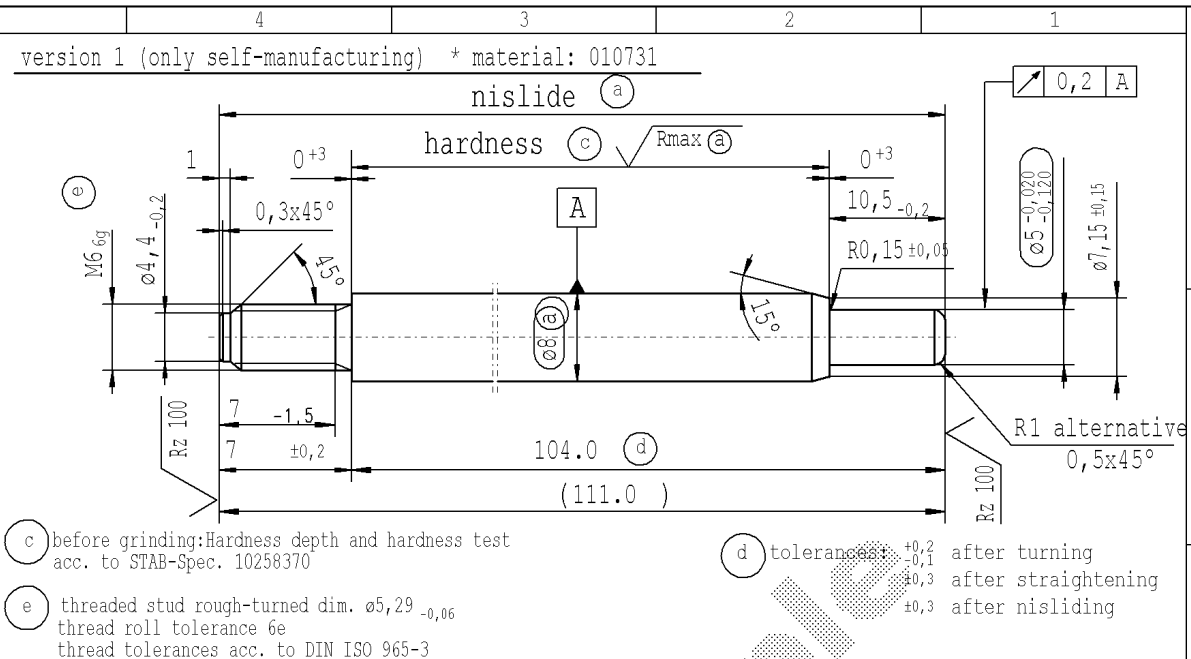

$\sqrt{Rz 25}$ ($\sqrt{Rz 100}$ $\sqrt{R_{max}}$ (a) \sqrt{Ra} (b) \sqrt{Rz} (b)) $\begin{matrix} +0,2 \\ -0,2 \end{matrix}$

sheet 1 of 2

AIAG CQI-standards acc. to STAB-Spec. 10027692				Environmental protection acc. to STAB-Spec. 10005649			
DE: X	EN: X	ES:	IT:	PR:	FR:	RO: X	CAD created document handwritten changes not permitted
new	approved lengths: 90-600 mm	⊙ = acc. STAB-Spec. 10258370		new format Internal/Supplier			
old	approved lengths: 90-400 mm	⊙ = RHT 0,4 ... 0,7 mm		Supplier drawing separately			
Field	D/4-5	B 4-5		-			
Date/Name	24.11.2015 Hein	15.05.2019 Donat		14.07.2020 Höfer			
Chg. No.	630576	678703		690118			
Rev.	6	7		8			
Material: *				All dimensions are in mm			
Edge tolerances acc. to DIN ISO 13715				Marking of special characteristics according to STAB-Spec. 10270932			
Surface finish DIN EN ISO 1302				Scale: (Original DIN A3) 2:1			
Replaces:				We reserve all rights to this document, to any patents or patent registrations related hereto, and to the duplication, retransmission by third parties and misc. use. Any use of this document is not permitted without the written consent of STABILUS.			
STABILUS				PISTON ROD			
				Date: 14.01.2008 Name: Höfer			
				Checked: 15.07.2020 Name: Klinkner			
				Document No.: 10151863			
				Material No.:			