

The print-out is not subject to the modification service.

Intended for internal and supplier use

Ident. Doc.:  
Date: 07.07.2010  
Date: 15.05.2019  
Date: 08.06.2020  
Date: 28.09.2009  
Date: 08.06.2020

supp No:	material no.			A	B	E
	processing and surface treatment acc. to STAB-Spec. 10006248 Tab. IV 10006248 Tab. X 10028959 Tab. I			overall length	thread length	length without end-fitting stud
	(a) version 1	(a) version 1	(b) version 2			
59		780844	780844	561	12	549
60	931894	931894	931894	123	10	113
61	937391	937391	937391	303	10	293
62	608531	608531	608531	267	10	257
63	304763	304763	304763	495	10	485
64	416615	416615	416615	333	10	323
65	902504	902504	902504	204	10	194
66	534923	534923	534923	453	10	443
67	296402	296402	296402	135	8	127
68	298075	298075	298075	114	8	106
69	389851	389851	389851	183	10	173
70	352090	352090	352090	204	12	192
71	979944	979944	979944	453	12	441
72	217057	217057	217057	300	8	292
73	864747	864747	864747	237	12	225
74	920912	920912	920912	315	12	303
75	685498	685498	685498	213	12	201
<b>76</b>	<b>330584</b>	<b>330584</b>	<b>330584</b>	<b>126</b>	<b>12</b>	<b>114</b>
77	334408	334408	334408	192	12	180

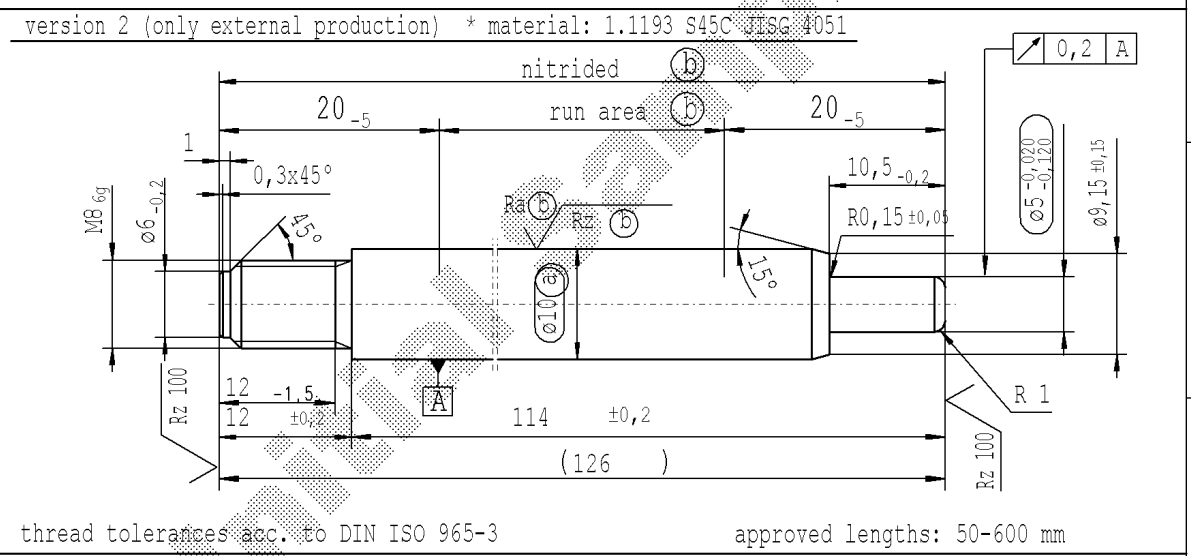
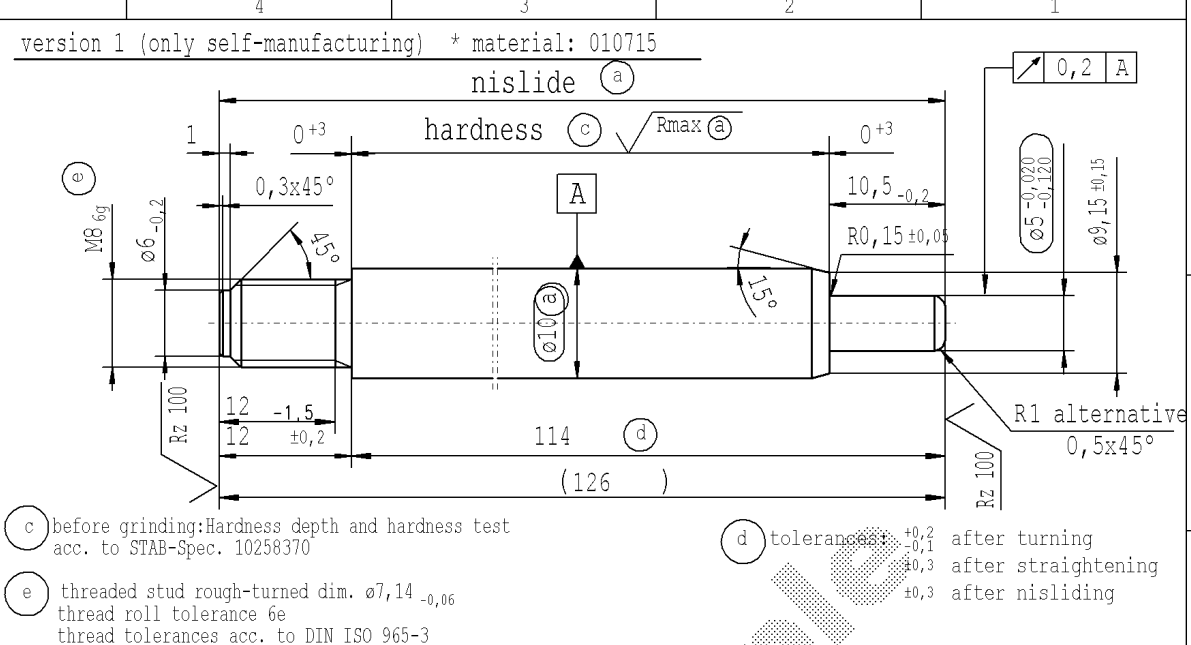

$\sqrt{Rz 25}$  ( $\sqrt{Rz 100}$   $\sqrt{R_{max}}$  (a)  $\sqrt{Ra}$  (b)  $\sqrt{Rz}$  (b))  $\begin{matrix} +0,2 \\ -0,2 \end{matrix}$

sheet 3 of 3

AIAG CQI-standards acc. to STAB-Spec. 10027692				Environmental protection acc. to STAB-Spec. 10005649			
DE: X	EN: X	ES:	IT:	PR:	FR:	RO: X	CAD created document handwritten changes not permitted
new	Table X completed	⊙ = acc. STAB-Spec. 10258370		new format Internal/Supplier			
old	-	⊙ = RHT 0,4 ... 0,7 mm		Supplier drawing separately			
Field	A-E/7-8	B 7-8		-			
Date/Name	07.07.2010 Höfer	15.05.2019 Donat		08.06.2020 Höfer			
Chg. No.	581405	678703		688987			
Rev.	2	3		4			
Material: *				All dimensions are in mm			
Edge tolerances acc. to DIN ISO 13715				Marking of special characteristics according to STAB-Spec. 10270932			
Surface finish DIN EN ISO 1302				Scale: (Original DIN A3) 2:1			
Replaces:				We reserve all rights to this document, to any patents or patent registrations related hereto, and to the duplication, retransmission by third parties and misc. use. Any use of this document is not permitted without the written consent of STABILUS.			
<b>STABILUS</b>				<b>PISTON ROD</b>			
				Date: 28.09.2009 Name: K.Marx			
				Checked: 08.06.2020 Klinkner			
				Document No.: 10166619			
				Material No.:			