

The print-out is not subject to the modification service.

Intended for internal and supplier use

Brevell Datum: 11/11/2020 - 11:10

Ident. Doc.:

supp No.	material no.			A	E
	processing and surface treatment acc. to STAB-Spec.			overall length	length without endfitting stud
	10006248 Tab. IV version 1	10006248 Tab. XVI version 1	10028959 Tab. I version 2		
1	432392	432392	432392	258	248.5
2	439801	439801	439801	159	149.5
3	603994	603994	603994	312	302.5
4	636502	636502	636502	306	296.5

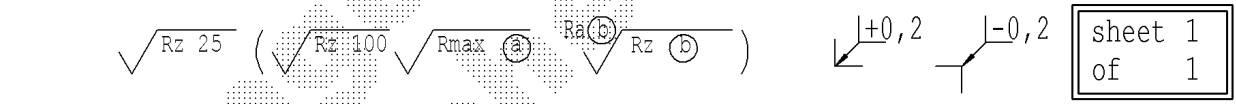
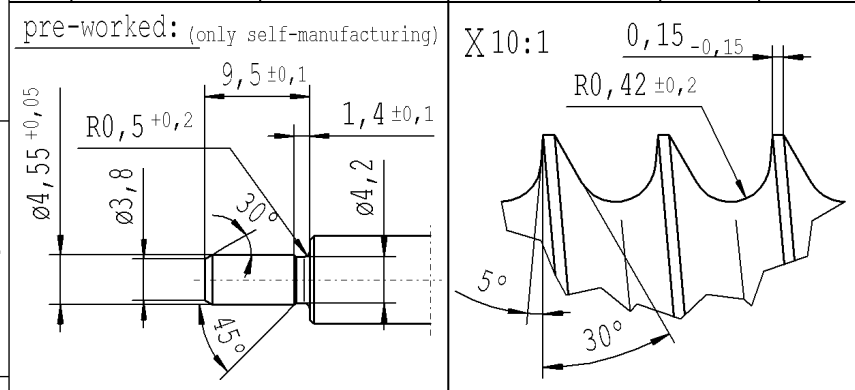
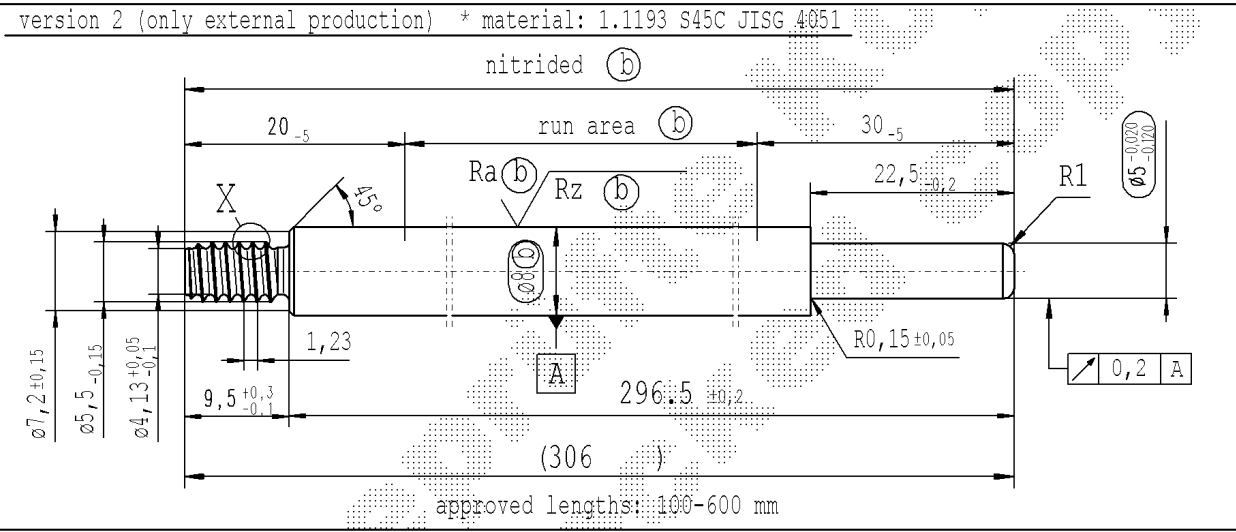
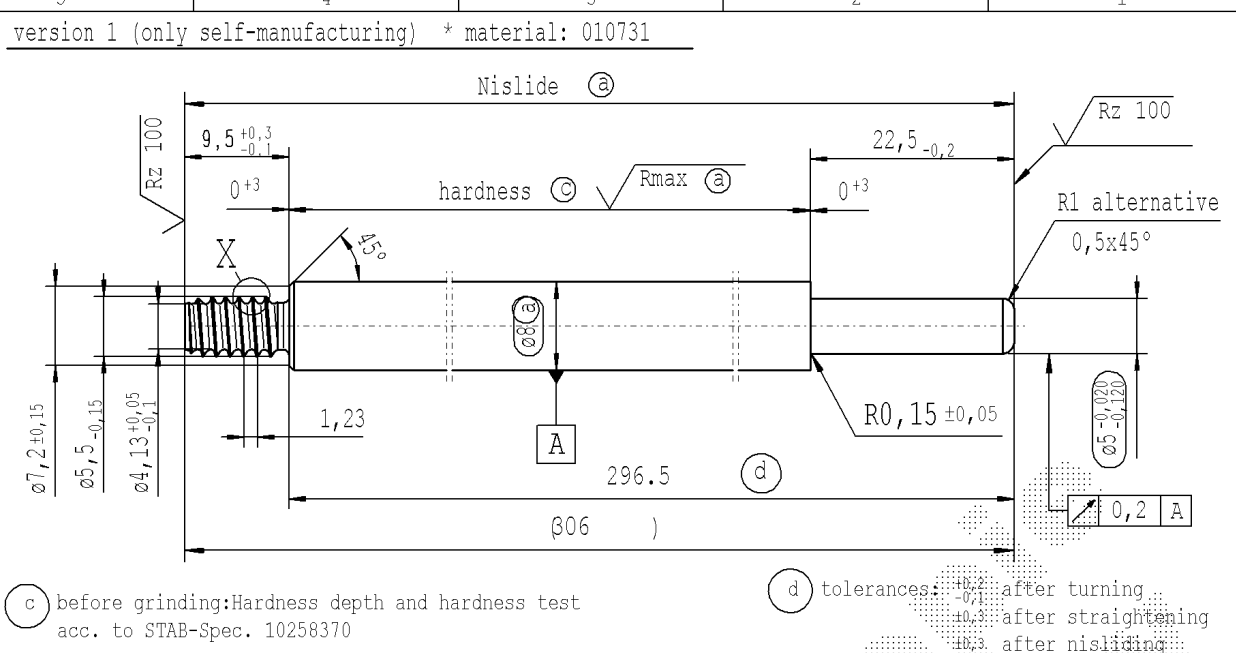

sheet 1 of 1

AIAG CQI-standards acc. to STAB-Spec. 10027692				Environmental protection acc. to STAB-Spec. 10005649									
DE: X	EN: X	ES:	IT:	PR:	FR:	RO: X	CAD created document handwritten changes not permitted	Material:	All dimensions are in mm	Marking of special characteristics according to STAB-Spec. 10270932	Date	Name	
new	INITIAL RELEASE	product family: 2020/0691		product family: 2020/0911		new format Internal/Supplier			Scale: (Original DIN A3) 2:1	Dimensions without tolerances DIN ISO 2768-mK	Drawn by	Höfer	
old	-	product family: 2019/xxxx		product family: 2019/0691		Supplier drawing separately		Edge tolerances acc. to DIN ISO 13715			Checked	10.11.2020	Klinkner
Field	-	B/5-6		B/5-6		-		Surface finish: DIN EN ISO 1302	We reserve all rights to this document, to any patents or patent registrations related hereto, and to the duplication, retransmission by third parties and misc. use. Any use of this document is not permitted without the written consent of STABILUS.			Document No.:	10269054
Date/Name	04.09.2019 Höfer	19.08.2020 Hein		03.11.2020 Donat		10.11.2020 Hein		Replaces:				Material No.:	
Chg. No.	-	690730		692432		691608							
Rev.	0	1		2		3		STABILUS	PISTON ROD				