

The print-out is not subject to the modification service.

Intended for internal and supplier use

Ident. Doc.: ERPEN11.dwg; 10/2/2021 - 9:30

supp No.	material no.		A	E
	processing and surface treatment acc. to STAB-Spec. 10006248 Tab.XVI version 1	10028959 Tab. I version 2		
20	043543	043543	177.0	168.5
21	167586	167586	240.0	231.5
22	381013	381013	249.0	240.5
23	396309	396309	151.0	142.5
24	396787	396787	255.0	246.5
25	397265	397265	123.0	114.5
26	397982	397982	270.0	261.5
27	410410	410410	167.5	159.0
28	415668	415668	300.0	291.5
29	420926	420926	369.0	360.5
30	422599	422599	150.0	141.5
31	437417	437417	132.0	123.5
32	438612	438612	129.0	120.5
33	443870	443870	256.0	247.5
34	444587	444587	228.0	219.5
35	457015	457015	204.0	195.5
36	465141	465141	191.0	182.5
37	467053	467053	174.0	165.5
38	483783	483783	207.0	198.5

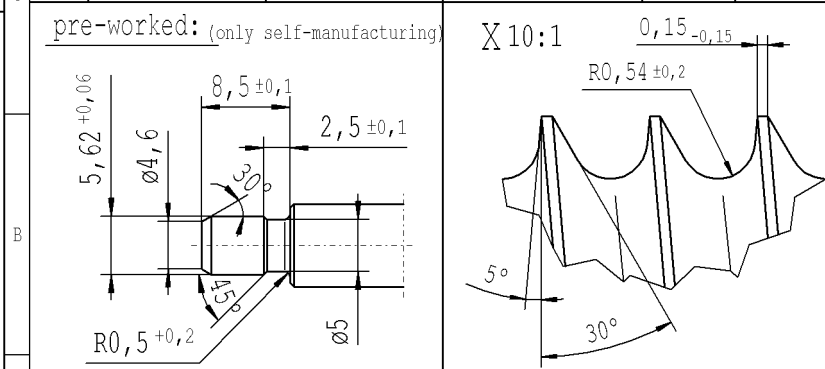
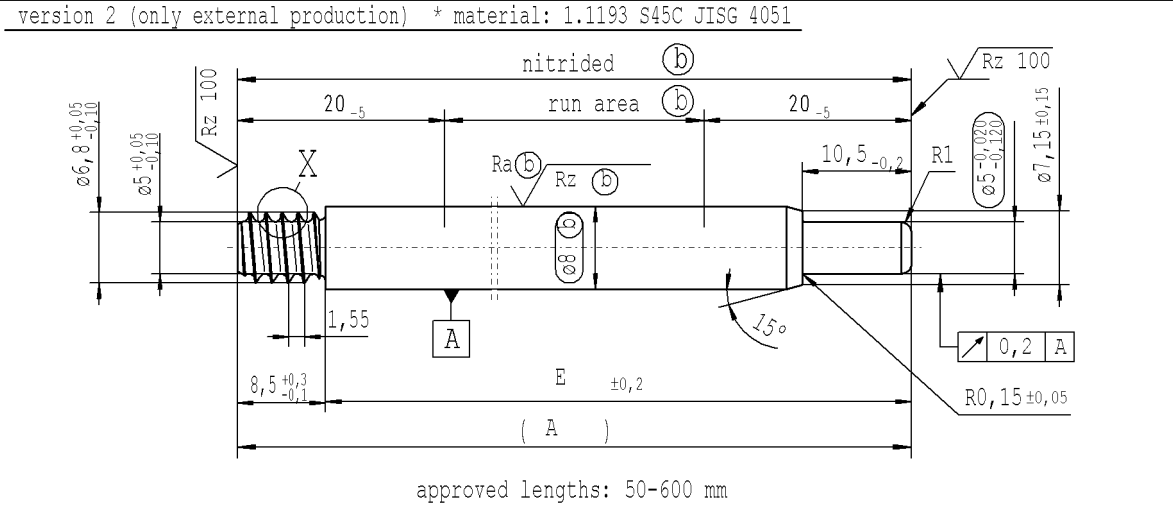
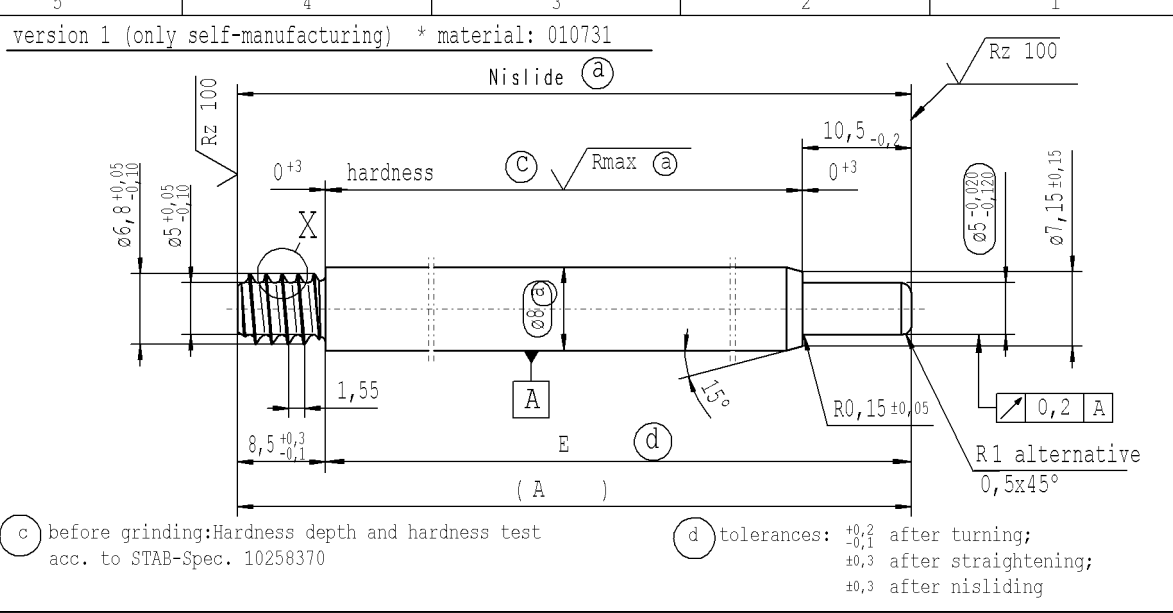

AIAG CQI-standards acc. to STAB-Spec. 10027692					Environmental protection acc. to STAB-Spec. 10005649						
DE: X	EN: X	ES:	IT:	PR: X	FR:	RO: X	Material: *	All dimensions are in mm	Marking of special characteristics according to STAB-Spec. 10270932	Date	Name
new	-	new format Internal/Supplier		CRD created document; handwritten changes not permitted			Surface finish DIN EN ISO 1302	Scale: (Original DIN A3) 2:1	Dimensions without tolerances DIN ISO 2768-mK	30.03.2017	vamueller
old	Tab IV	Supplier drawing separately		±0,2; no technical change, no new first sample required			Edge tolerances acc. to DIN ISO 13715			03.02.2021	Klinkner
Field	A-F 8	-		B/3			Replaces:	We reserve all rights to this document, to any patents or patent registrations related hereto, and to the duplication, retransmission by third parties and misc. use. Any use of this document is not permitted without the written consent of STABILUS.			
Date/Name	13.06.2019 Höfer	20.03.2020 Höfer		03.02.2021 Hein				Document No.: 10243257			
Chg. No.	678620	687201		694938				Material No.:			
Rev.	4	5		5			<b>STABILUS</b>	<b>PISTON ROD</b>			

sheet 2 of 3