

The print-out is not subject to the modification service.

Intended for internal and supplier use

EN

Ident. Doc.:

supp No.	material no.			A	E
	10006248 Tab. IV (a) version 1	10006248 Tab. X (a) version 1	10028959 Tab. I (b) version 2		
42		208888	208888	354.0	344.5
43	439286		439286	229.0	219.5
44	440003	440003	440003	240.0	230.5
45	440242		440242	217.0	207.5
46	440481		440481	226.0	216.5
47	441437	441437	441437	211.0	201.5
48	441915	441915	441915	150.0	140.5
49	442632	442632	442632	215.0	205.5
50		681394	681394	191.0	181.5
51	134085	134085	134085	155	145.5
52		764088	764088	304.0	294.5
53		764327	764327	257.0	247.5
54		969150	969150	159.0	149.5
55		377387	377387	236.0	226.5
56		455301	455301	156.0	146.5
57		456496	456496	129.0	119.5
58		460320	460320	226.0	216.5
59		463427	463427	150.0	140.5
60		468685	468685	261.0	251.5

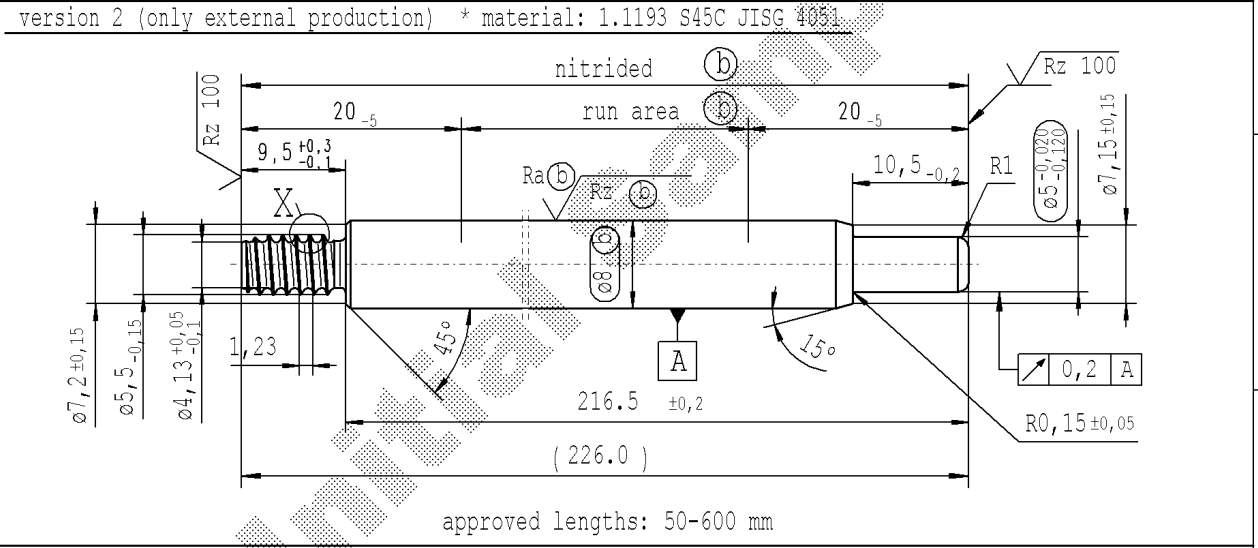
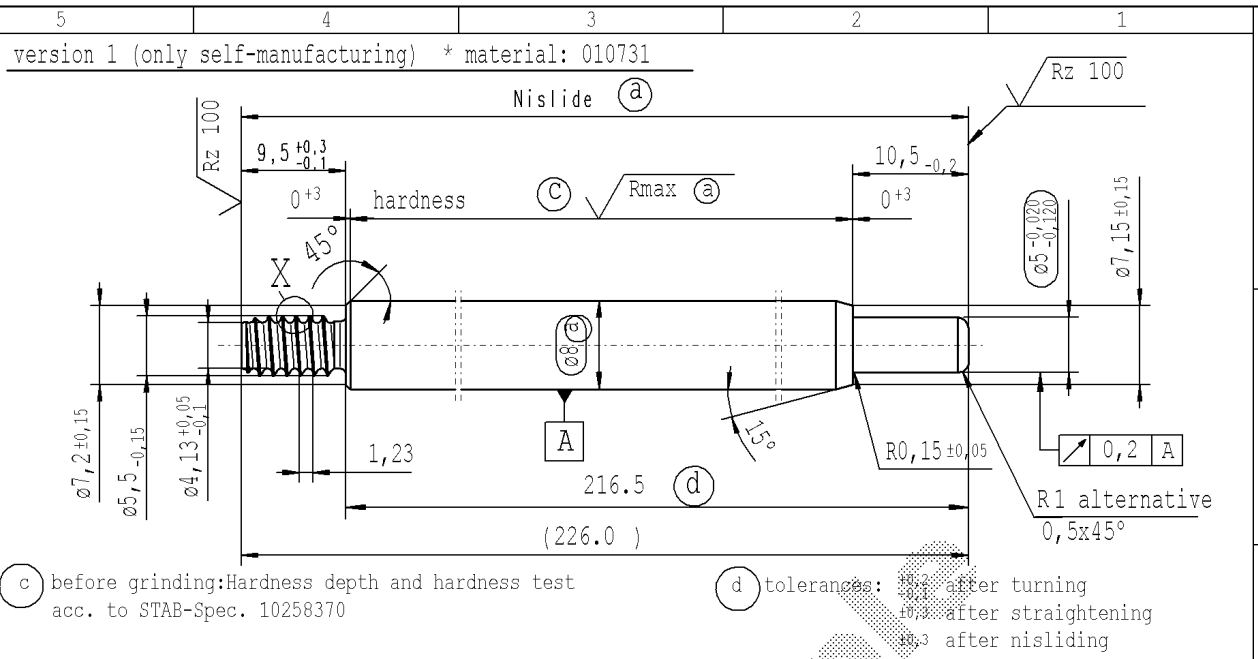

pre-worked: (only self-manufacturing)

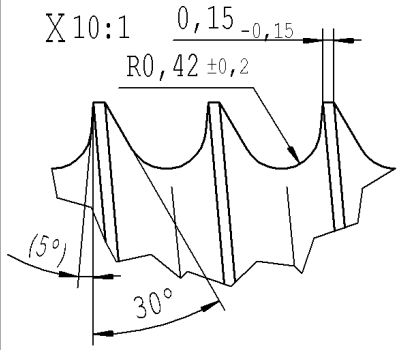
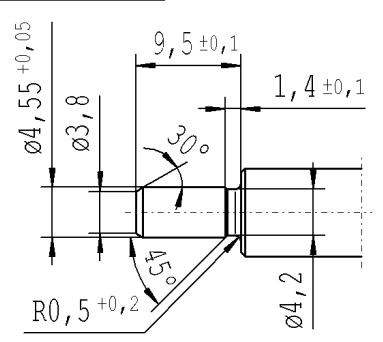

AIAG CQI-standards acc. to STAB-Spec. 10027692				Environmental protection acc. to STAB-Spec. 10005649			
DE: X	EN: X	ES:	IT:	PR: X	FR:	RO: X	CAD created document handwritten changes not permitted
new	© = acc. STAB-Spec. 10258370		new format Internal/Supplier		(5°) no technical change, no new first sample required		
old	© = RHT 0,4 ... 0,7 mm		Supplier drawing separately		5°		
Field	B 4-5		-		B/7		
Date/Name	15.05.2019 Jablonski		17.03.2020 Höfer		08.04.2021 Hein		
Chg. No.	678682		687147		696926		
Rev.	13		14		14		
Material: *				All dimensions are in mm			
Edge tolerances acc. to DIN ISO 13715				Marking of special characteristics according to STAB-Spec. 10270932			
Surface finish DIN EN ISO 1302				Date: 05.12.2007 Name: Höfer			
Replaces:				Checked: 08.04.2021 Klinkner			
STABILUS				Document No.: 10151066			
PISTON ROD				Material No.:			

sheet 3 of 8