

The print-out is not subject to the modification service.

Intended for internal and supplier use

EN

Ident. Doc.:

Date/Name

supp No.	material no.			A	E
	10006248 Tab. IV version 1	10006248 Tab. X version 1	10028959 Tab. I version 2		
80	201257	201257	201257	192.0	182.5
81	135533	135533	135533	168.0	158.5
82	611382	611382	611382	177.0	167.5
83	077935	077935	077935	159.5	150.0
84	088451	088451	088451	165.5	156.0
85	147486	147486	147486	114.0	104.5
86	440263	440263	440263	102.0	92.5
87	440502	440502	440502	300.0	290.5
88	440741	440741	440741	402.0	392.5
89	450779	450779	450779	501.0	491.5
90	451018	451018	451018	600.0	590.5
91	265076	265076	265076	249.0	239.5
92	345619	345619	345619	429.0	419.5
93	382425	382425	382425	141.0	131.5
94	104708	104708	104708	188.0	178.5
95	105903	105903	105903	204.0	194.5
96	108771	108771	108771	273.0	263.5
97	114268	114268	114268	157.0	147.5
98	117136	117136	117136	135.5	126.0

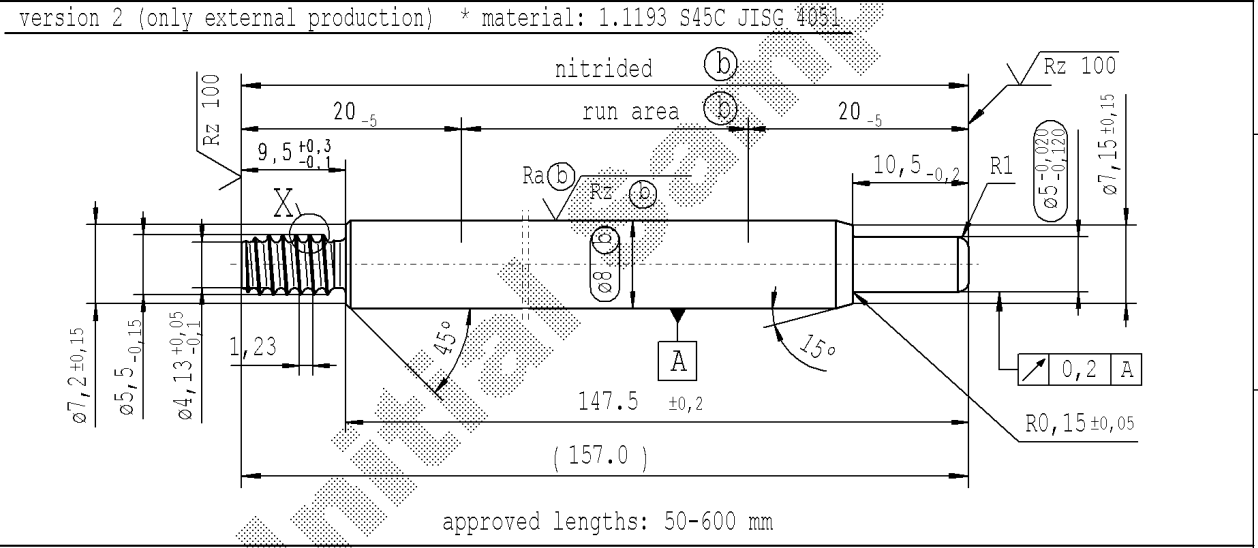
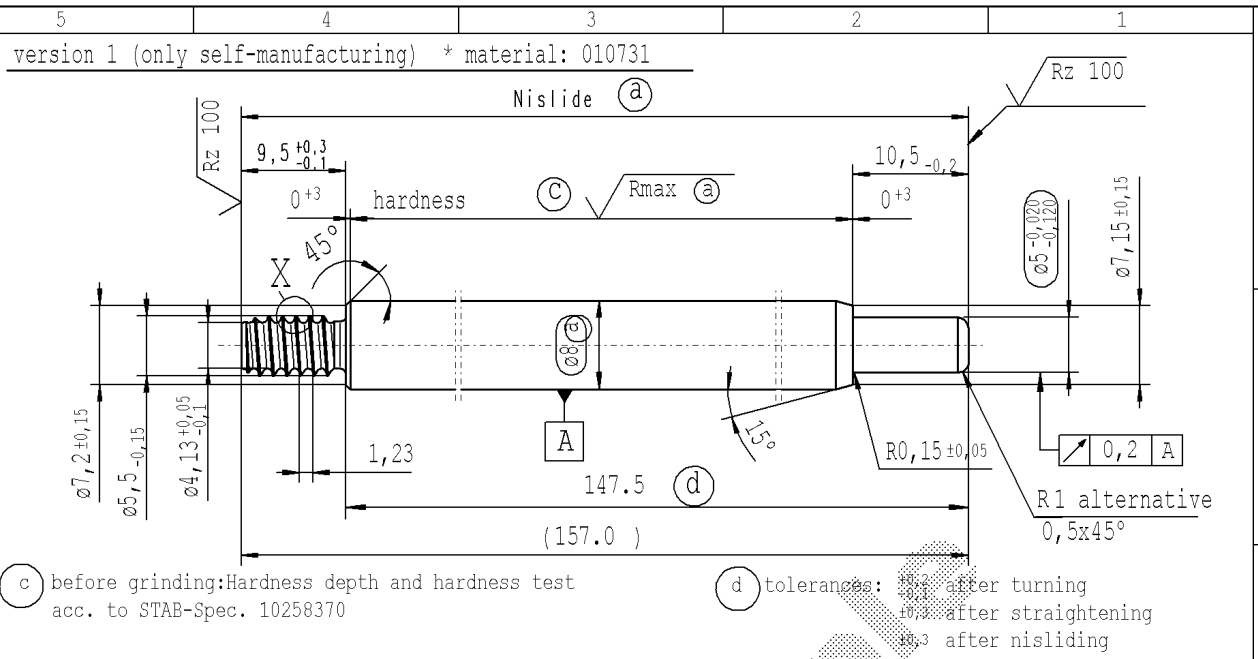

pre-worked: (only self-manufacturing)

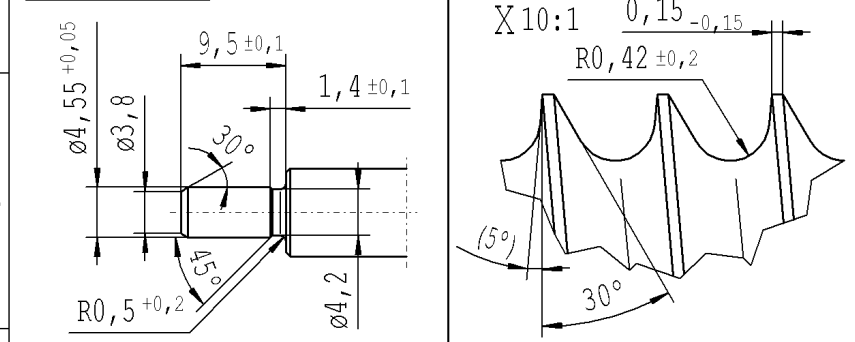

AIAG CQI-standards acc. to STAB-Spec. 10027692

DE: X	EN: X	ES:	IT:	PR: X	FR:	RO: X	CAD created document handwritten changes not permitted	Material: *	All dimensions are in mm	Marking of special characteristics according to STAB-Spec. 10270932	Date	Name
new	© = acc. STAB-Spec. 10258370			new format Internal/Supplier			(5°) no technical change, no new first sample required		Scale: (Original DIN A3) 2:1	Dimensions without tolerances DIN ISO 2768-mK	Drawn by	Höfer
old	© = RHT 0,4 ... 0,7 mm			Supplier drawing separately			5°	Edge tolerances acc. to DIN ISO 13715			Checked	Klinkner
Field	B 4-5			-			B/7	Surface finish DIN EN ISO 1302			Document No.:	10151066
Date/Name	15.05.2019 Jablonski			17.03.2020 Höfer			08.04.2021 Hein	Replaces:			Material No.:	
Chg. No.	678682			687147			696926					
Rev.	13			14			14	STABILUS		PISTON ROD		

sheet 5 of 8