

The print-out is not subject to the modification service.

Intended for internal and supplier use

Ersatzlfdnr.: 19/2/2021 - 14128

Ident. Doc.:

supp No.	material no.	overall length
	Surface treatment STAB-Spec. 10028959 Tab.I Ⓟ	A
1	201986	138
2	897482	252
3	898438	129
4	499071	150
5	763645	216
6	246213	153
7	375751	165
8	906332	84
9	100425	330
10	100664	273
11	104010	228
12	911591	201
13	441479	369
14	481870	141
15	483543	123
16	484499	180
17	492625	171
18	916612	162
19	918524	222
20	919958	192
21	923304	270
xx	xxxxxxx	279

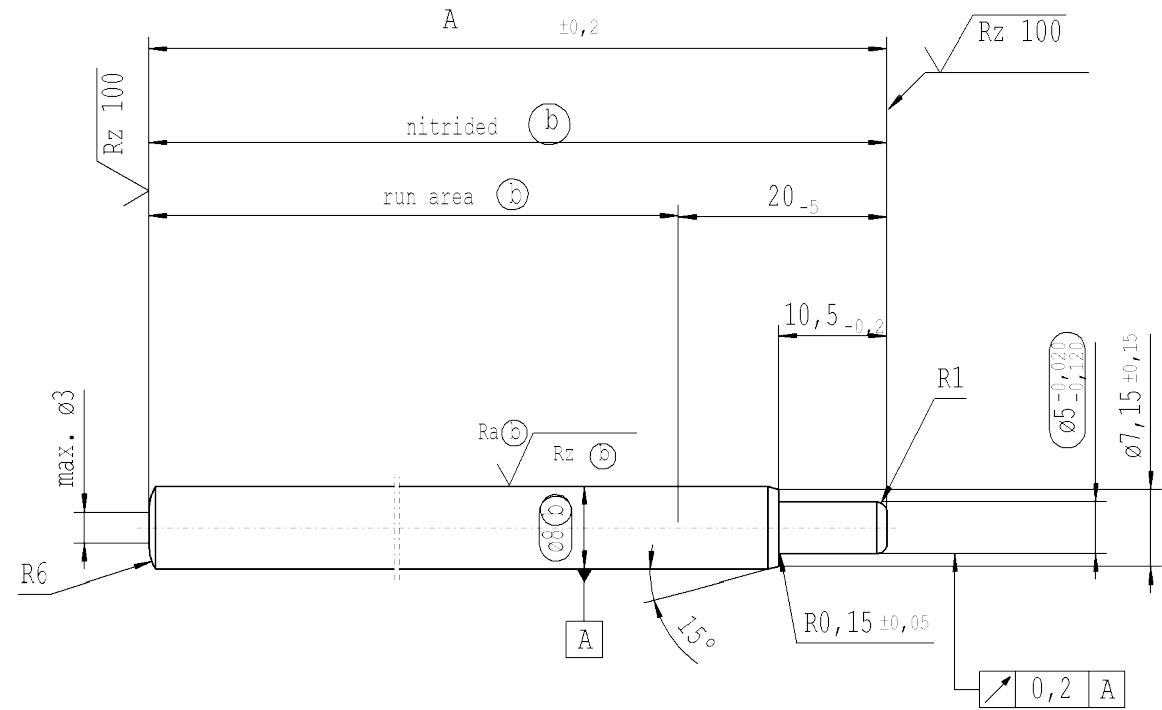

external production * material: 1.1193 S45C JISG 4051

approved lengths: 50-600 mm

√Rz 25 (√Rz 100 Ra Ⓟ Rz Ⓟ) √±0,2 √-0,2

sheet 1
of 1

AIAG CQI-standards acc. to STAB-Spec. 10027692										Environmental protection acc. to STAB-Spec. 10005649													
DE: X	EN: X	ES:	IT:	FR:	FR:	RO: X	CRD created document; handwritten changes not permitted			Material:	*			All dimensions are in mm			Marking of special characteristics according to STAB-Spec. 10270932			Date	Name		
new	revised	product family: 2019/0334				Ⓟ = acc. STAB-Spec. 10258370	new format Supplier						Scale: (Original DIN A3) 2:1			Dimensions without tolerances DIN ISO 2768-mK			Drawn by	06.03.2017	Höfer		
old	-	product family: 2018/xxxx				Ⓟ = RHT 0,4 ... 0,7 mm	Supplier drawing separately			Edge tolerances acc. to DIN ISO 13715						Checked			09.11.2020	Klinkner			
Field	-	C/5-6				B 5-6			Surface finish DIN EN ISO 1302						We reserve all rights to this document, to any patents or patent registrations related hereto, and to the duplication, retransmission by third parties and misc. use. Any use of this document is not permitted without the written consent of STABILUS.			Document No.:			10242572		
Date/Name	17.09.2018 Höfer	10.04.2019 Hein				08.05.2019 Höfer			09.11.2020 Donat			Replaces:						Material No.:					
Chg. No.	671841	677737				678170			692739			STABILUS			PISTON ROD								
Rev.	1	2				3			4														