

The print-out is not subject to the modification service.

Intended for internal and supplier use

EN

Ident. Doc.:

supp No.	material no.			A	B
	processing and surface treatment acc. to STAB-Spec.: 10006248 Tab. IV 10006248 Tab. X 10028959 Tab. I			overall length	stud length end-fitting side
	(a) version 1	(a) version 1	(b) version 2		
1	377908	377908		407.5	16

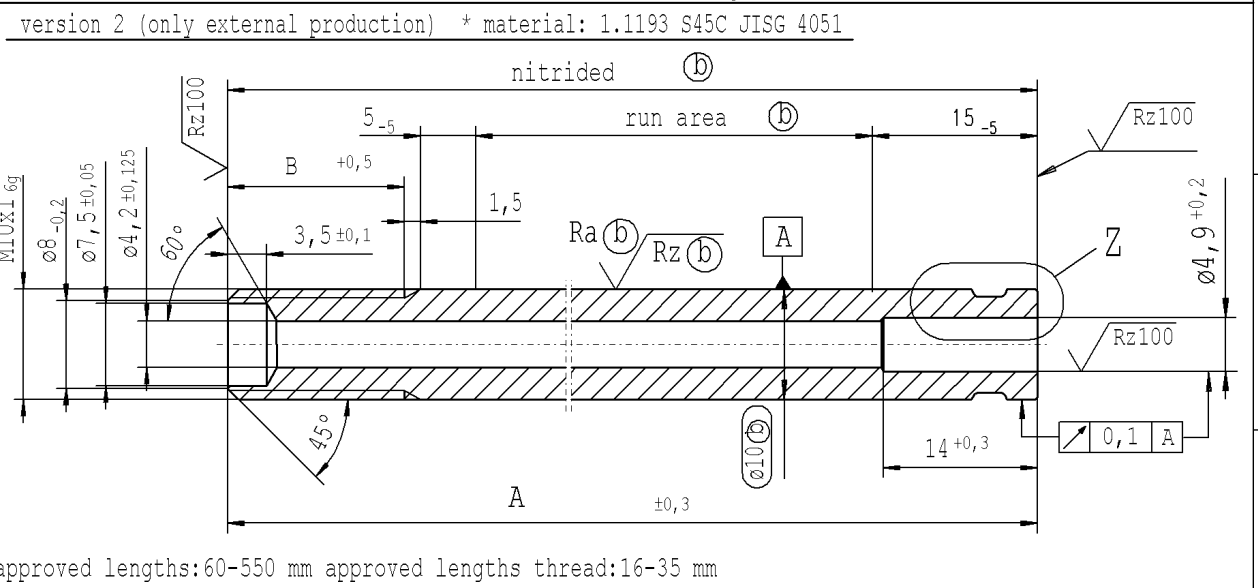
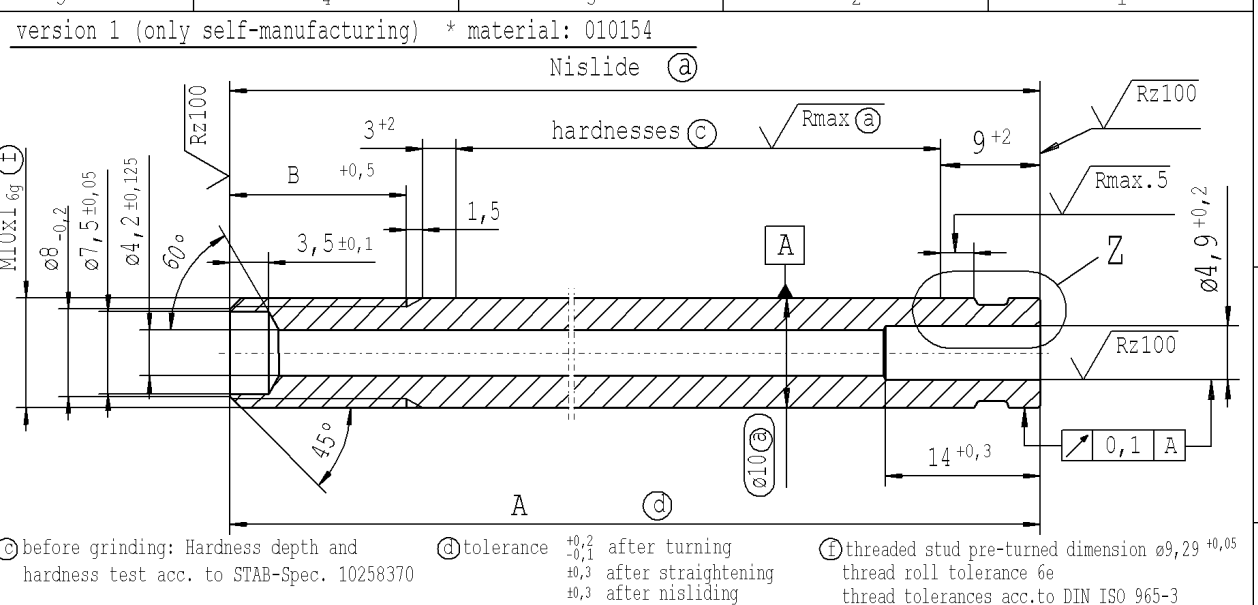

100% cleanliness of through hole

Rz 25 (Rz 100 Rmax5 Rmax (a) Ra (b) Rz (b)) (+0,2 / -0,2 / ±0,1) sheet 1 of 1

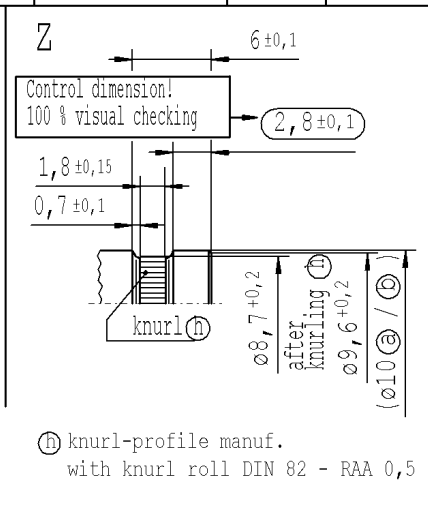
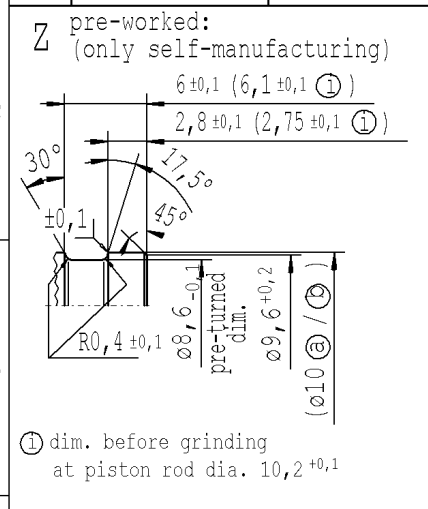

AIAG CQI-standards acc. to STAB-Spec. 10027692										Environmental protection acc. to STAB-Spec. 10005649																	
DE: X	EN: X	ES:	IT:	PR:	FR:	RO: X	CAD created document; handwritten changes not permitted										Material: *	All dimensions are in mm									
new	INITIAL RELEASE																Edge tolerances acc. to DIN ISO 13715	Marking of special characteristics according to STAB-Spec. 10270932									
old	-																Surface finish DIN EN ISO 1302	Scale: (Original DIN A3) 2:1									
Field	-																Replaces: 10015662	We reserve all rights to this document, to any patents or patent registrations related hereto, and to the duplication, retransmission by third parties and misc. use. Any use of this document is not permitted without the written consent of STABILUS.									
Date/Name	05.07.2021 Hein																STABILUS	PISTON ROD									
Chg. No.	699945																Document No.: 10294944										
Rev.	0																Material No.:										