

The print-out is not subject to the modification service.

Intended for internal and supplier use

EN

Ident. Doc.:

supp No.	material no.			A	B	E
	10006248 Tab. XVI optimized version 1	10006248 Tab. X version 1	10028959 Tab. I version 2	overall length	thread length	length without end-fitting stud
60	041865	041865	041865	234.0	7	227.0
61	102579	102579	102579	75.0	7	68.0
62	190292	190292	190292	255.0	7	248.0
63	259363	259363	259363	147.0	7	140.0
64	278722	278722	278722	89.0	7	82.0
65	560264	560264	560264	163.0	7	156.0
66	655625	655625	655625	84.0	7	77.0
67	155878	155878	155878	117.0	7	110.0
68	163526	163526	163526	267.0	7	260.0
69	209175	209175	209175	156.0	7	149.0
70	336562	336562	336562	288.0	7	281.0
71	342537	342537	342537	99.0	7	92.0
72	345405	345405	345405	174.5	7	167.5
73	349707	349707	349707	342.0	7	335.0
74	350185	350185	350185	118.5	7	111.5
75	351141	351141	351141	90.0	7	83.0
76	354965	354965	354965	204.0	7	197.0
77	357116	357116	357116	252.0	7	245.0
78	366915	366915	366915	247.0	7	240.0
79	373129	373129	373129	251.0	7	244.0
80	374085	374085	374085	121.5	7	114.5
81	384601	384601	384601	312.0	7	305.0
82	386035	386035	386035	216.0	7	209.0
83	436942	436942	436942	327.0	7	320.0
84	439571	439571	439571	107.0	7	100.0
85	456301	456301	456301	303.0	7	296.0
86	473270	473270	473270	309.0	7	302.0
87	477333	477333	477333	72.0	7	65.0
88	480201	480201	480201	315.0	7	308.0

version 1 (only self-manufacturing) * material: 010731

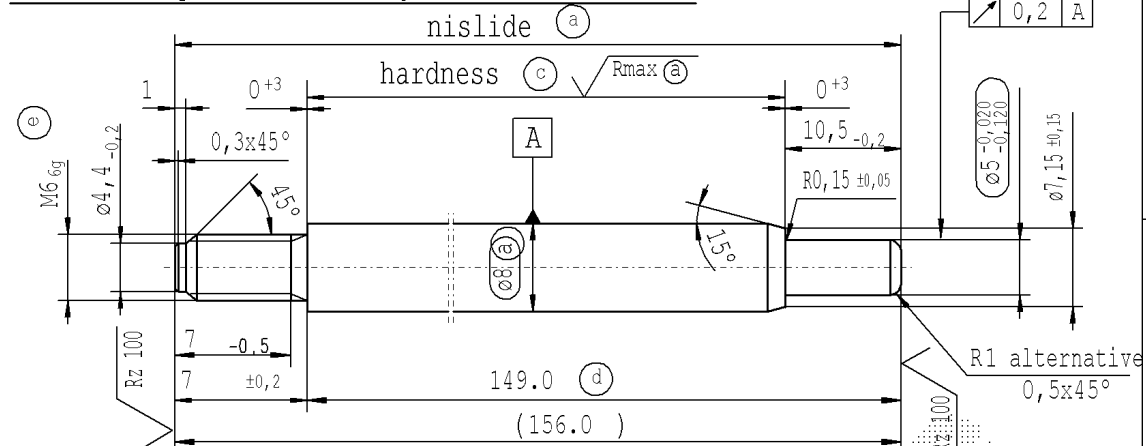

(c) before grinding: Hardness depth and hardness test acc. to STAB-Spec. 10258370
 (d) tolerances: ± 0.2 after turning
 ± 0.3 after straightening
 ± 0.3 after nisliding
 (e) threaded stud rough-turned dim. $\varnothing 5,29_{-0,06}$
 thread roll tolerance 6e
 thread tolerances acc. to DIN ISO 965-3

version 2 (only external production) * material: 1.1193 S45C JISG 4051

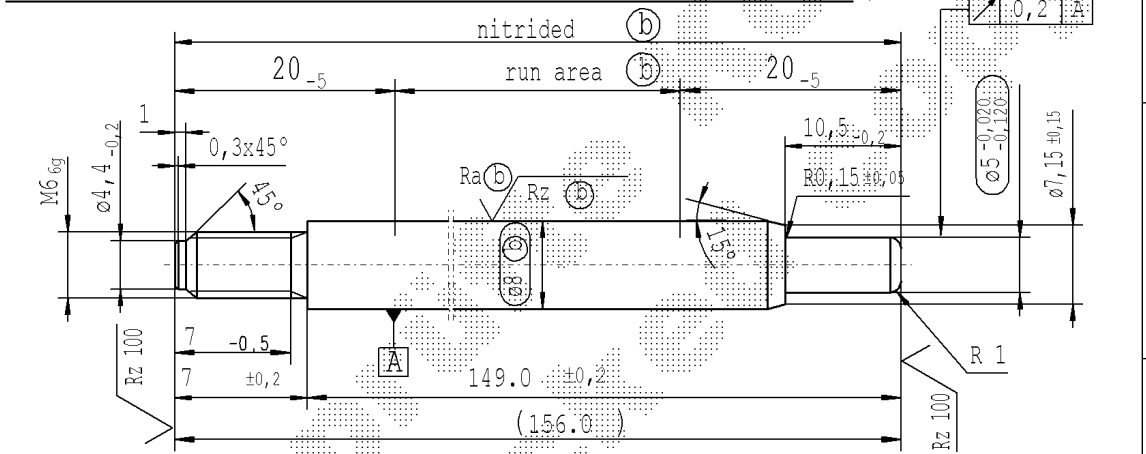

thread tolerances acc. to DIN ISO 965-3 approved lengths: 50-600 mm

$\sqrt{Rz 25}$ ($\sqrt{Rz 100}$ \sqrt{Rmax} (a) Ra (b) Rz (b)) $\pm 0,2$ $\pm 0,2$

sheet 3 of 4

AIAG CQI-standards acc. to STAB-Spec. 10027692

Environmental protection acc. to STAB-Spec. 10005649

DE: X	EN: X	ES:	IT:	PR:	FR:	RO: X	CAD created document handwritten changes not permitted	Material: *
new	no technical change, no new first sample required		ø8 b no technical change, no new first sample required					Edge tolerances acc. to DIN ISO 13715
old	Tab XVI		ø8 a					Surface Finish: DIN EN ISO 1302
Field	F 7		C/3					Replaces:
Date/Name	14.09.2021 Donat		11.11.2021 Hein					
Chg. No.	700848		703194					
Rev.	9		9					

All dimensions are in mm	Marking of special characteristics according to STAB-Spec. 10270932	Date	Name
Scale: (Original DIN A3) 2:1	Dimensions without tolerances DIN ISO 2768-mK	Drawn by	14.01.2008 Höfer
We reserve all rights to this document, to any patents or patent registrations related hereto, and to the duplication, retransmission by third parties and misc. use. Any use of this document is not permitted without the written consent of STABILUS.		Checked	11.11.2021 Klinkner
		Document No.:	10151863
		Material No.:	

STABILUS

PISTON ROD