

The print-out is not subject to the modification service.

Intended for internal and external use

EN

B

A

Ident. Doc.:

supp No.	material no.		A
	surface treatment processing acc. to STAB-Spec. 10006248 table V Nislide light	surface treatment processing acc. to STAB-Spec. 10028959 table II	
	Version 1	Version 2	overall length
94	196698	196698	210.0
95	543966	543966	441.0
98	861601	861601	117.0
100	223953	223953	171.0
101	425191	425191	396.0
102	519835	519835	150.0
103	319793	319793	285.0
104	690961	690961	201.0
105	168986	168986	348.0
106	945019	945019	147.0
107	970353	970353	276.0
108	039927	039927	189.0
109	147477	147477	195.0
110	203403	203403	204.0
111	239731	239731	183.0
112	293745	293745	192.0
113	661805	661805	180.0
114	739719	739719	135.0
115	856112	856112	225.0
116	871647	871647	207.0
117	874037	874037	318.0

Version 1 (only self-manufacturing)

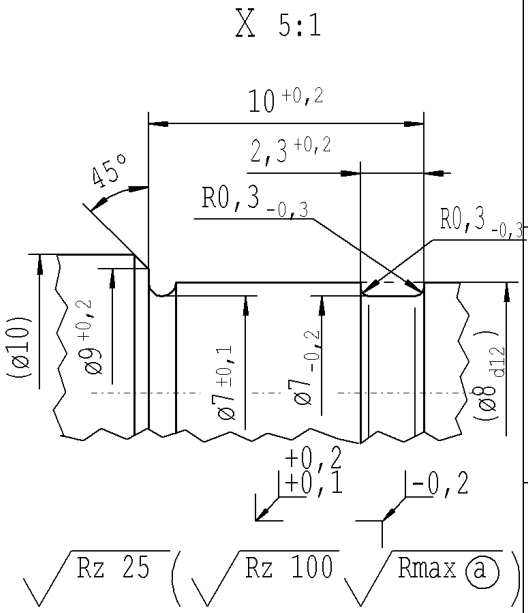
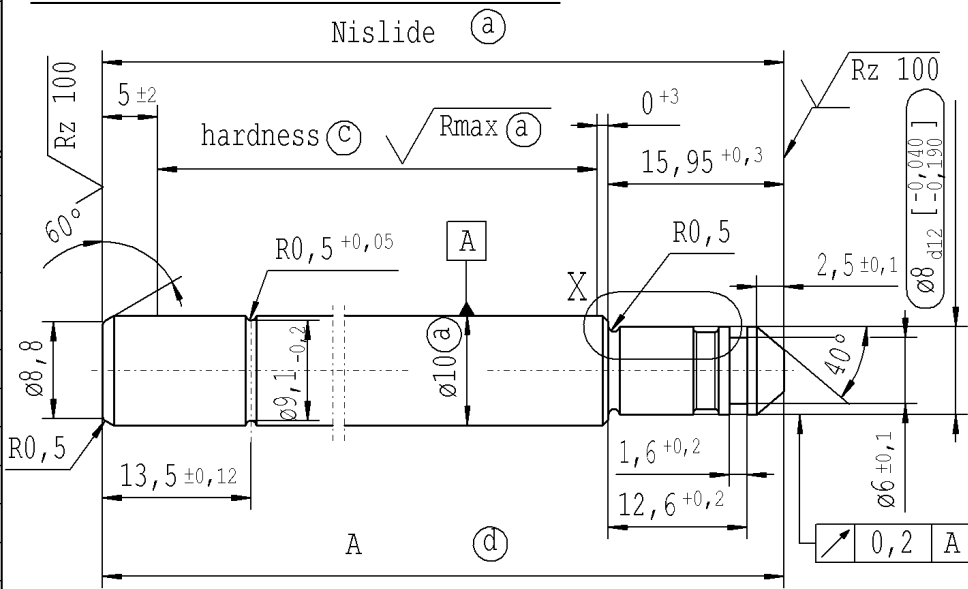

Version 2 (only external manufacturing)

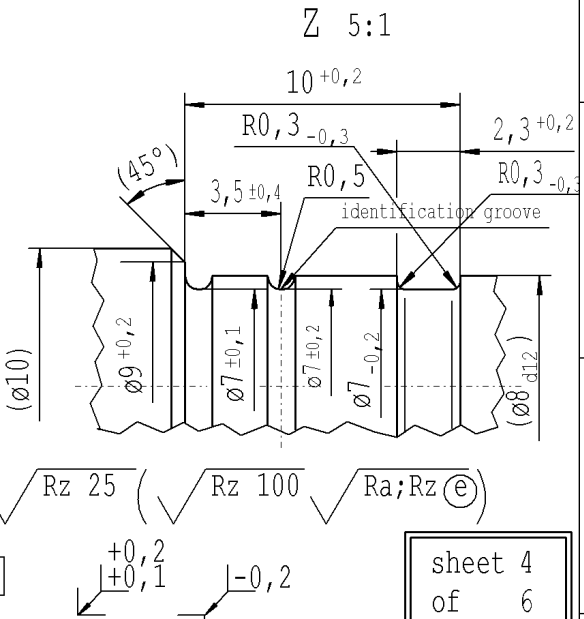
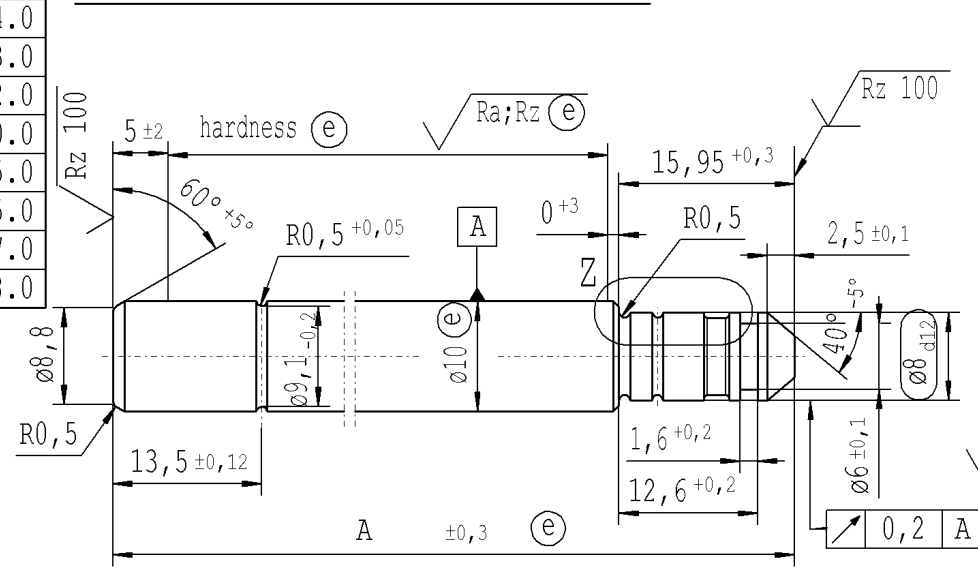

Ⓒ before grinding:
Hardness depth and hardness test acc. to STAB-Spec. 10258370

Ⓓ tolerance $\begin{matrix} +0,2 \\ -0,1 \end{matrix}$ after turning
 $\pm 0,3$ after straightening
 $\pm 0,3$ after nisliding

Environmental protection acc. to STAB-Spec. 10005649

DE: X	EN: X	ES:	IT:	PR:	FR:	RO: X	CAD created document; handwritten changes not permitted
new	3,5±0,4	.8619TK	8652TV;8717YN;90527B;90877M;9658PX;2492UB;1511V;7789VU	Ⓒ = acc. STAB-Spec. 10258370	new format Internal/Supplier		
old	3,5±0,2	DOK 10023735 Pos.29	was on Dok.10023735	Ⓒ = RHT 0,4 0,7 mm	Supplier drawing separately		
Field	E2	Pos.28	Tab.Pos. 29-36	B 7-8	-		
Date/Name	25.10.06 KeB.	12.01.2007 H8	24.4.07 ReB.	14.05.2019 Jablonski	10.02.2021 Jablonski		
Chg. No.	548667	554410	556213	678684	695144		
Rev.	4	5	6	7	8		

Material: Version 1: Mat.No. 010715 Version 2 : 1.1193	All dimensions are in mm	Marking of special characteristics according to STAB-Spec. 10270932	Date 11.02.2005	Name KeBelheim
Edge tolerances acc. to DIN ISO 13715	Scale: (Original DIN A3) 2:1	Dimensions without tolerances DIN ISO 2768 mK	Checked 10.02.2021	C.Banciu
Surface finish DIN EN ISO 1302	We reserve all rights to this document, to any patents or patent registrations related hereto, and to the duplication, retransmission by third parties and misc. use. Any use of this document is not permitted without the written consent of STABILUS.		Document No.: 10028756	
Replaces:	STABILUS		Material No.:	

PISTON ROD	
------------	--

sheet 4
of 6