

The print-out is not subject to the modification service.

Intended for internal and supplier use

EN

Ident. Doc.:

Date: 31/03/2022 - 7:15

supp No.	material no.			A	E
	processing and surface treatment acc. to STAB-Spec. 10006248 Tab. XVI optimized version 1	10006248 Tab. X version 1	10028959 Tab. I version 2	overall length	length without endfitting stud
328	989988	989988	989988	210.0	201.5
329	054065	054065	054065	198.0	189.5
330	150860	150860	150860	163.5	155.0
331	169741	169741	169741	123.0	114.5
332	223038	223038	223038	387.0	378.5
333	282788	282788	282788	358.0	349.5
334	462038	462038	462038	288.0	279.5
335	483070	483070	483070	273.0	264.5
336	504341	504341	504341	147.0	138.5
337	505297	505297	505297	224.5	216.0
338	507926	507926	507926	263.5	255.0
339	508404	508404	508404	246.5	238.0
340	518681	518681	518681	229.0	220.5
341	557638	557638	557638	281.0	272.5
342	641527	641527	641527	244.0	235.5
343	797116	797116	797116	194.0	185.5
344	797594	797594	797594	296.5	288.0
345	848979	848979	848979	241.5	233.0
346	853042	853042	853042	260.0	251.5

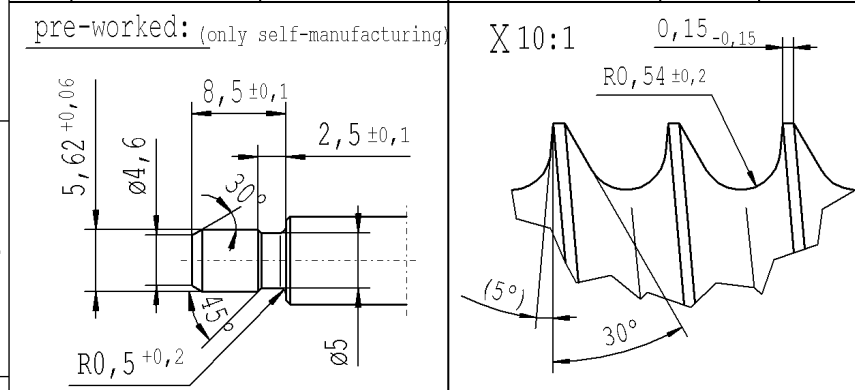
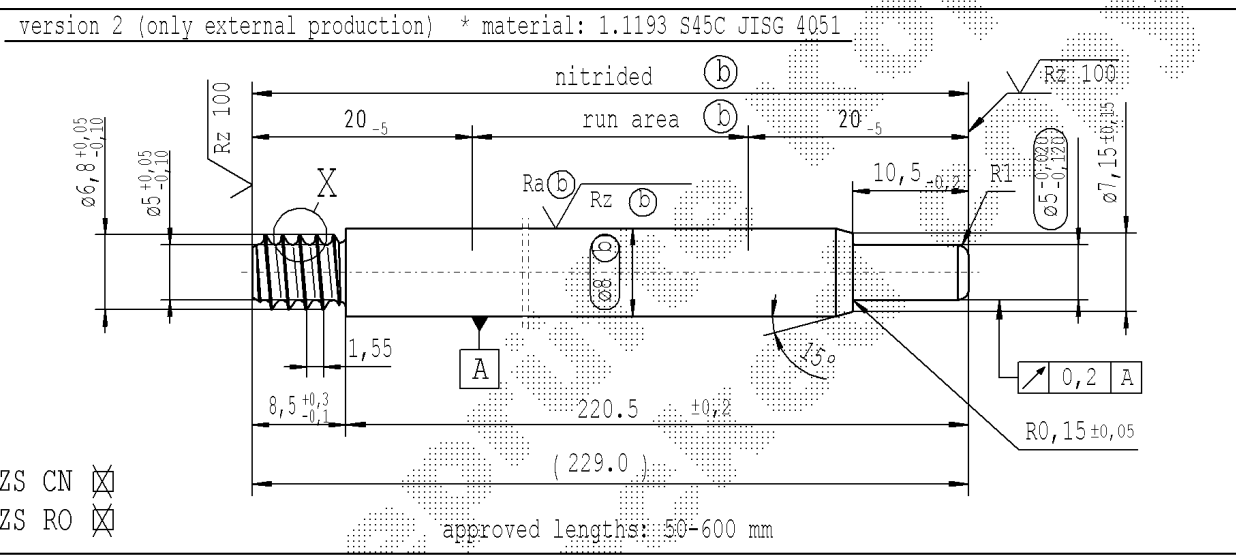
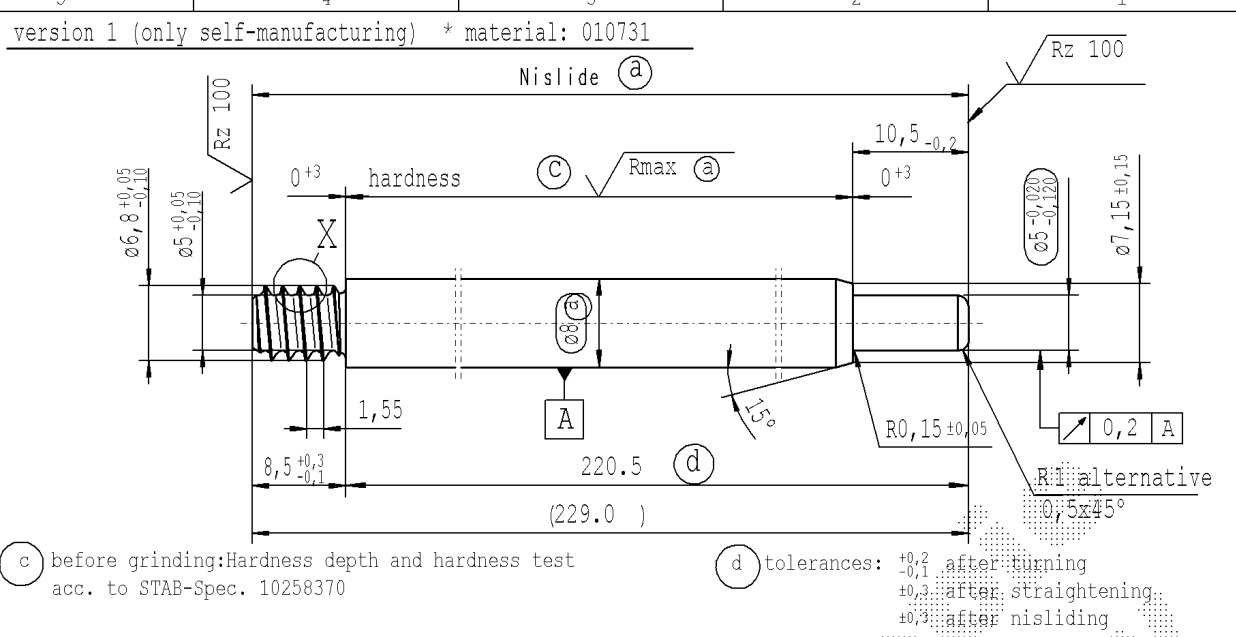

ZS CN  ZS RO

sheet 16 of 20

DE: X				EN: X				ES:				IT:				PR: X				FR:				RO: X				CAD created document handwritten changes not permitted				Material: <b>X</b>				All dimensions are in mm				Marking of special characteristics according to STAB-Spec. 10270932				Date: 05.12.2007				Name: Höfer			
new				Tab XVI no technical change, no new first sample required				ZS CN / ZS RO no technical change, no new first sample required				-				-				-				-				-				Scale: (Original DIN A3) 2:1				Dimensions without tolerances DIN ISO 2768-mK				Checked: 11.03.2022				Klinkner							
old				Tab IV				-				-				-				-				-				-				-				-				-				-							
Field				F 8				B/5				-				-				-				-				-				-				-				-				-							
Date/Name				12.08.2021 Donat				10.03.2022 Hein				-				-				-				-				-				-				-				-				-							
Chg. No.				699704				707979				-				-				-				-				-				-				-				-				-							
Rev.				21				21				-				-				-				-				-				-				-				-				-							
Ident. Doc.:				10151065				-				-				-				-				-				-				-				-				-				-							