

The print-out is not subject to the modification service.

Intended for internal and supplier use

EN

Brevet.datum: 30/11/2021 - 9:50

Ident. Doc.:

supp No.	material no.			A	E
	processing and surface treatment acc. to STAB-Spec. 10006248 Tab. XVI optimized version 1	10006248 Tab. X version 1	10028959 Tab. I version 2	overall length	length without unfitting stud
148	763610	763610	763610	266.0	257.5
149	763849	763849	763849	285.0	276.5
150	988987	988987	988987	324.0	315.5
151	996396	996396	996396	336.0	327.5
152	454823	454823	454823	282.0	273.5
153	459603	459603	459603	305.0	296.5
154	461037	461037	461037	186.0	177.5
155	462949	462949	462949	203.5	195.0
156	464383	464383	464383	224.0	215.5
157	464861	464861	464861	253.0	244.5
158	466295	466295	466295	136.0	127.5
159	466773	466773	466773	265.0	256.5
160	501906	501906	501906	291.0	282.5
161	751900	751900	751900	414.0	405.5
162	755007	755007	755007	297.0	288.5
163	885023	885023	885023	441.0	432.5
164		060713	060713	273.0	264.5
165	061669	061669	061669	381.0	372.5
167	245221	245221	245221	363.0	354.5

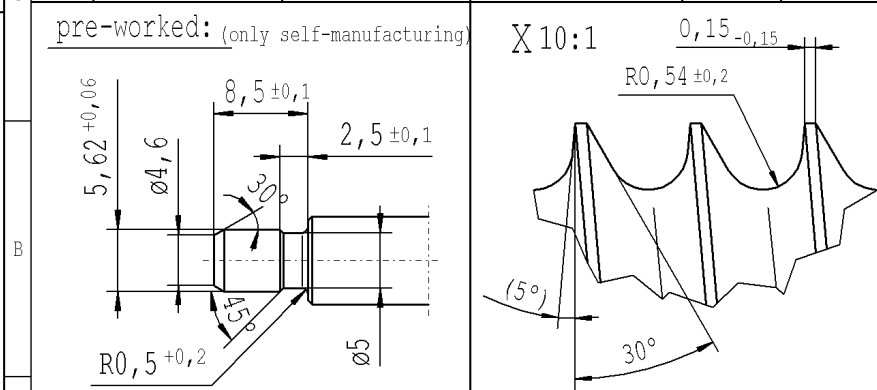

pre-worked: (only self-manufacturing) X 10:1

DE: X	EN: X	ES:	IT:	PR: X	FR:	RO: X	CAD created document; handwritten changes not permitted	Material: *	All dimensions are in mm	Marking of special characteristics according to STAB-Spec. 10270932	Date	Name
new	(5°); no technical change, no new first sample required						Tab XVI; no technical change, no new first sample required		Scale: (Original DIN A3) 2:1	Dimensions without tolerances DIN ISO 2768-mK	Drawn by	Höfer
old				5°			Tab IV;	Edge tolerances acc. to DIN ISO 13715			Checked	Milles
Field				B/6-7			F 8	Surface finish DIN EN ISO 1302				
Date/Name				31.03.2021 Hein			12.08.2021 Donat	Replaces:				Document No.:
Chg. No.				696924			699704					10151065
Rev.				21			21					Material No.:

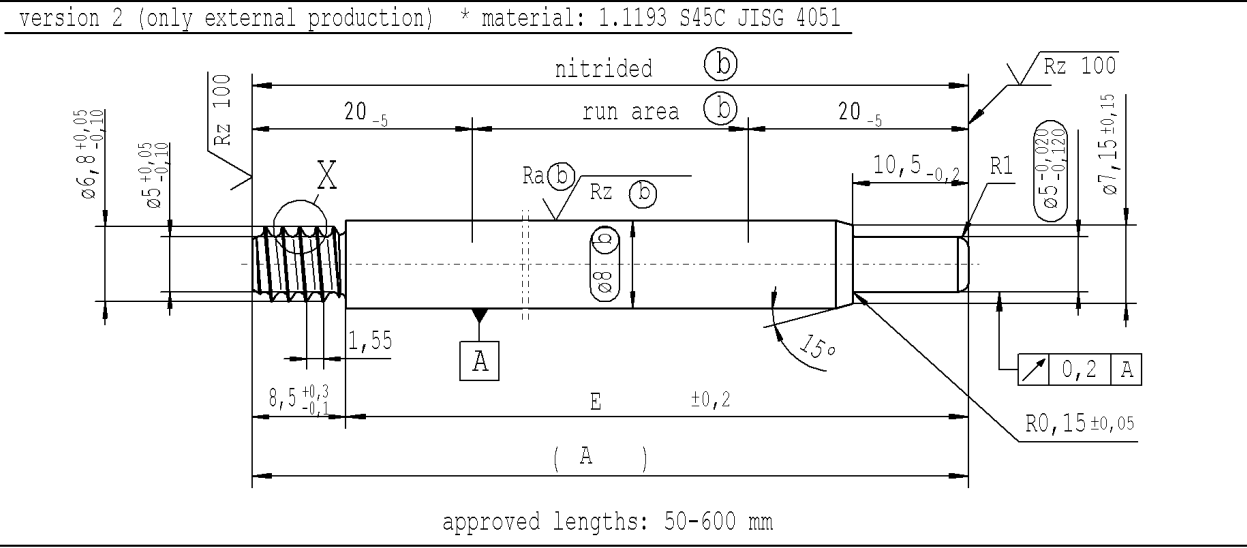
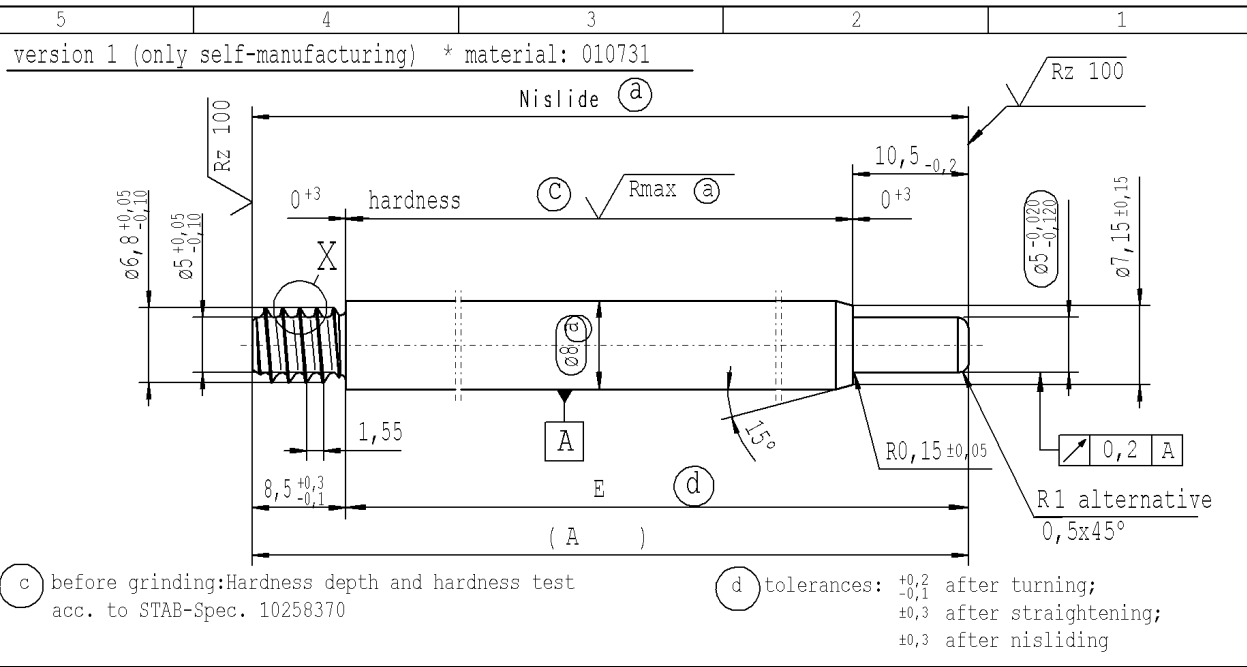

√ Rz 25 (√ Rz 100 √ Rmax (a) Ra (b) Rz (b)) ± 0,2 ∓ 0,2

sheet 8 of 16

STABILUS

PISTON ROD