

The print-out is not subject to the modification service.

Intended for internal and supplier use

Ident. Doc.:

supp No.	material no.		A	E
	(a) version 1	(b) version 2	overall length	length without endfitting stud
1	143925	143925	204	196
2	508405	508405	195	187
3	221129	221129	180	172
4	378630	378630	192	184

version 1 (only self-manufacturing) \* material: 010707

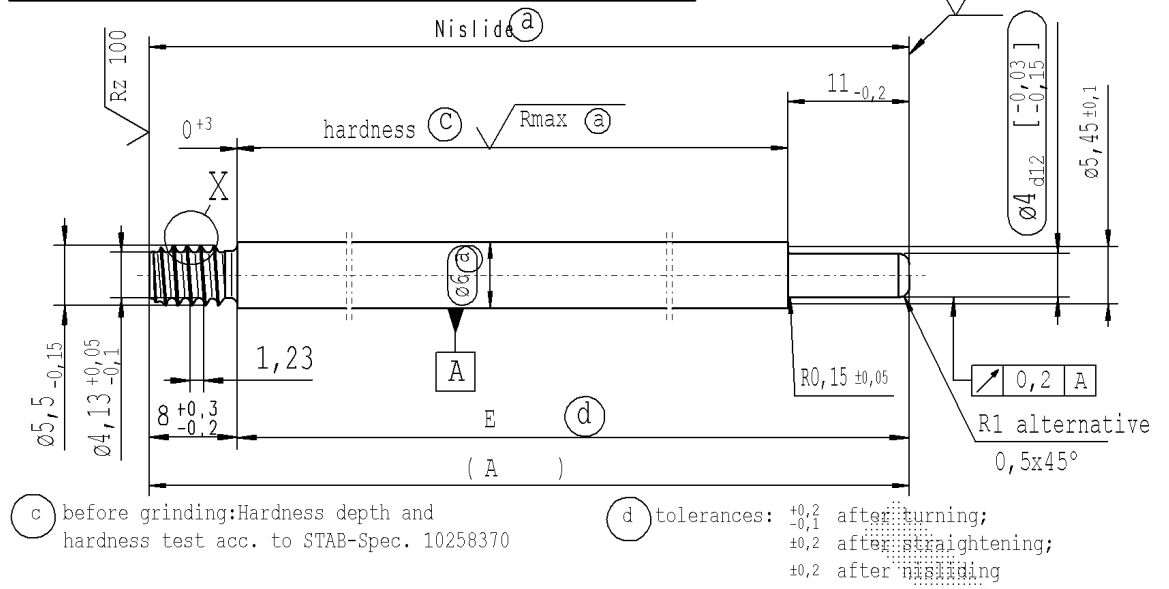

version 2 (only external production) \* material: 1.1193 S45C JISG 4051

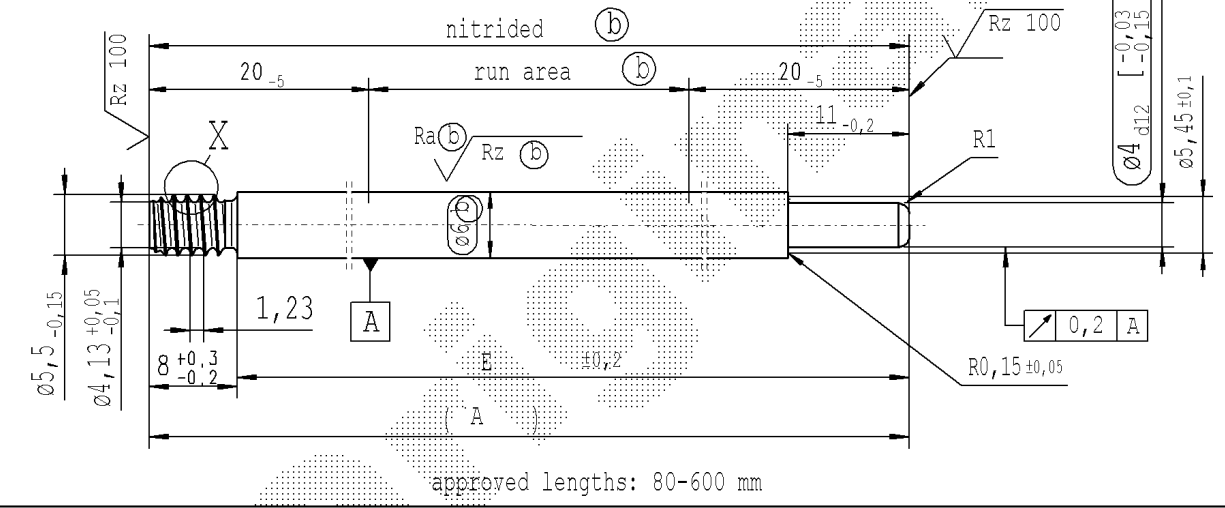

pre-worked: (only self-manufacturing)

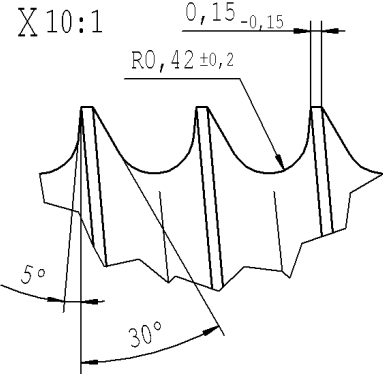
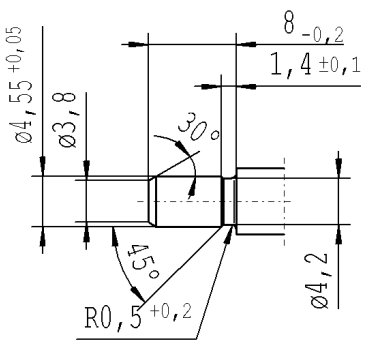

AIAG CQI-standards acc. to STAB-Spec. 10027692

Environmental protection acc. to STAB-Spec. 10005649

DE: X	EN: X	ES:	IT:	PR:	FR:	RO: X	CAD created document; handwritten changes not permitted
new	Initial Release	Tab X deleted, no technical change, no new first sample required					
old	-						
Field	-						
Date/Name	30.11.2020 Donat		31.05.2021 Jablonski				
Chg. No.	-		697821				
Rev.	0		0				

Material:	*
Edge tolerances acc. to DIN ISO 13715	
Surface finish	DIN EN ISO 1302
Replaces:	
<b>STABILUS</b>	

All dimensions are in mm	Marking of special characteristics according to STAB-Spec. 10270932
Scale: (Original DIN A3) 2:1	Dimensions without tolerances DIN ISO 2768-mK
We reserve all rights to this document, to any patents or patent registrations related hereto, and to the duplication, retransmission by third parties and misc. use. Any use of this document is not permitted without the written consent of STABILUS.	
Document No.: 10283692	
Material No.:	

sheet 1 of 1

PISTON ROD