

The print-out is not subject to the modification service.

Intended for internal and supplier use

Erzteilenummer: 31.01.2022 - 8:48

Ident. Doc.:

supp No.	material no.			A	B
	processing and surface treatment acc. to STAB-Spec.: 10006248 Tab. IV 10006248 Tab. X 10028959 Tab. I	overall length	stud length end-fitting side		
	(a) version 1	(a) version 1	(b) version 2		
113		825080	825080	416.5	16
114		825558	825558	206.5	16
115		827231	827231	266.5	16
116		829143	829143	293.5	16
117		829621	829621	236.5	16
118	837030		837030	479.5	16
119		837508	837508	299.5	16
120		837986	837986	233.5	16
121		841093	841093	227.5	16
122		842288	842288	287.5	16
123		844678	844678	296.5	16
124		845395	845395	272.5	16
125		845873	845873	230.5	16
126		246701	246701	280.5	16
127	848741		848741	500.5	16
128	849697		849697	503.5	16

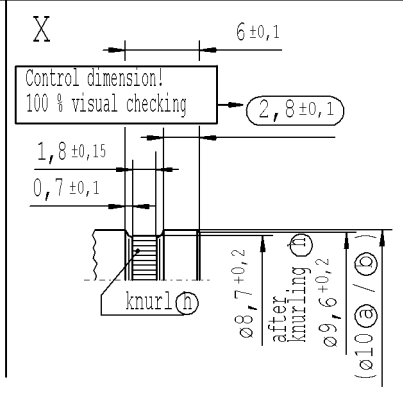
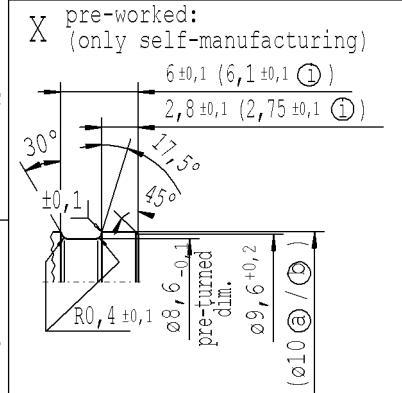

① dim. before grinding at piston rod dia. 10,2 + 0,1

Ⓜ knurl-profile manuf. with knurl roll DIN 82 - RAA 0,5

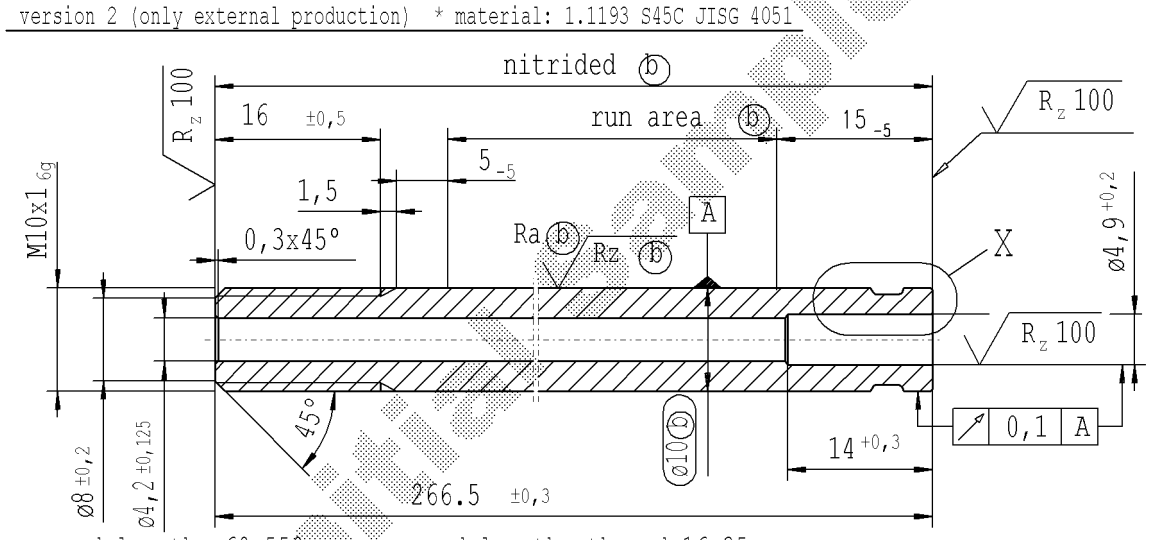
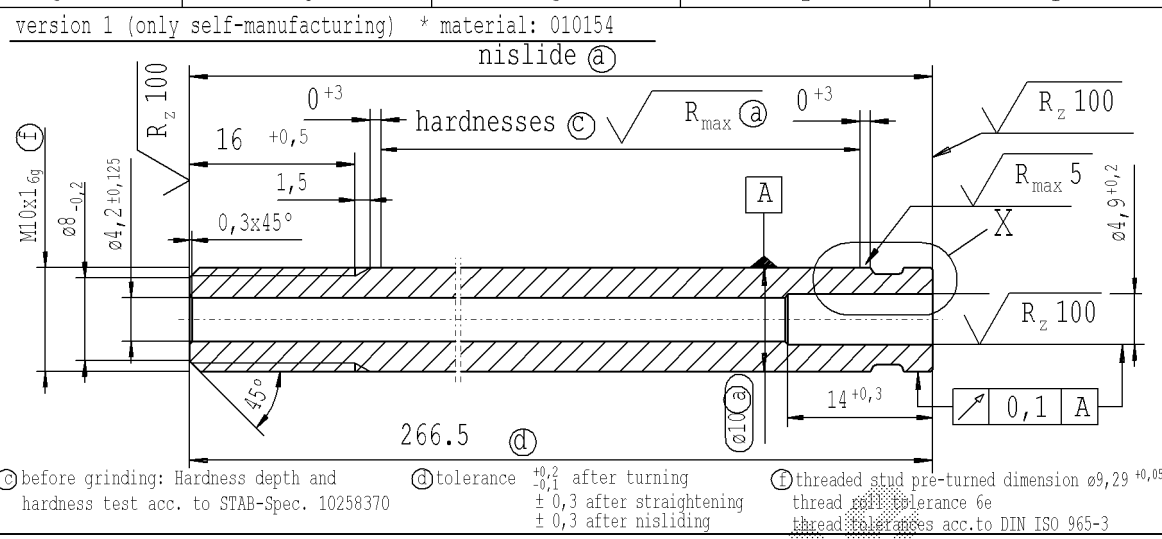

approved lengths: 60-550 mm approved lengths thread: 16-35 mm

100% cleanliness of through hole

√ Rz 25 (√ Rz 100 √ Rmax 5 √ Rmax (a) Ra (b) Rz (b))

sheet 8 of 15

DE: X				EN: X				ES: X				IT: X				PR: X				FR: X				RO: X				Material: *				All dimensions are in mm				Marking of special characteristics according to STAB-Spec. 10270932				Date				Name			
new				thread roll tolerance 6e				ⓐ = acc. STAB-Spec. 10258370				new format Internal/Supplier				B ± 0,5				Edge tolerances acc. to DIN ISO 13715				Scale: (Original DIN A3) 2:1				Dimensions without tolerances DIN ISO 2768-mK				Drawn by				Date				Name							
old				thread roll tolerance 6g				ⓐ = RHT 0,4 0,7 mm				Supplier drawing separately				B ± 0,5				Surface finish DIN EN ISO 1302				We reserve all rights to this document, to any patents or patent registrations related hereto, and to the duplication, retransmission by third parties and misc. use. Any use of this document is not permitted without the written consent of STABILUS.				Checked				Date				Name											
Field				B8				C 7-8				-				D/4				Replaces:				Document No.:				10152095				Material No.:															
Date/Name				16.06.2015 Donat				15.05.2019 Donat				25.06.2021 Jablonski				24.02.2022 Hein				STABILUS				PISTON ROD																							
Chg. No.				639400				678703				698250				707230																															
Rev.				6				7				8				9																															