

The print-out is not subject to the modification service.

Intended for internal and external use

EN

B

A

Ident. Doc.:

| supp No. | material no. | | A |
|----------|--|---|----------------|
| | surface treatment processing acc. to STAB-Spec. 10006248 table V Nislide light | surface treatment processing acc. to STAB-Spec. 10028959 table II | |
| | Version 1 | Version 2 | overall length |
| 70 | 002491 | 002491 | 315.0 |
| 71 | 002498 | 002498 | 360.0 |
| 72 | 002504 | 002504 | 312.0 |
| 73 | 002520 | 002520 | 309.0 |
| 74 | 002536 | 002536 | 255.0 |
| 75 | 002543 | 002543 | 258.0 |
| 76 | 002812 | 002812 | 290.0 |
| 77 | 002835 | 002835 | 270.0 |
| 78 | 006065 | 006065 | 273.0 |
| 80 | 006537 | 006537 | 321.0 |
| 81 | 007090 | 007090 | 216.0 |
| 84 | 007262 | 007262 | 252.0 |
| 85 | 007880 | 007880 | 306.0 |
| 86 | 007898 | 007898 | 102.0 |
| 87 | 008145 | 008145 | 120.0 |
| 88 | 012571 | 012571 | 237.0 |
| 89 | 015122 | 015122 | 333.0 |
| 90 | 027635 | 027635 | 84.0 |
| 91 | 026171 | 026171 | 378.0 |
| 92 | 033040 | 033040 | 96.0 |
| 93 | 699826 | 699826 | 411.0 |

Version 1 (only self-manufacturing)

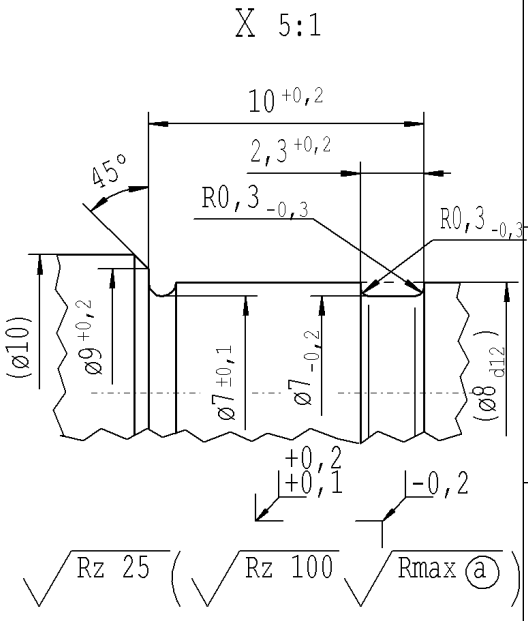
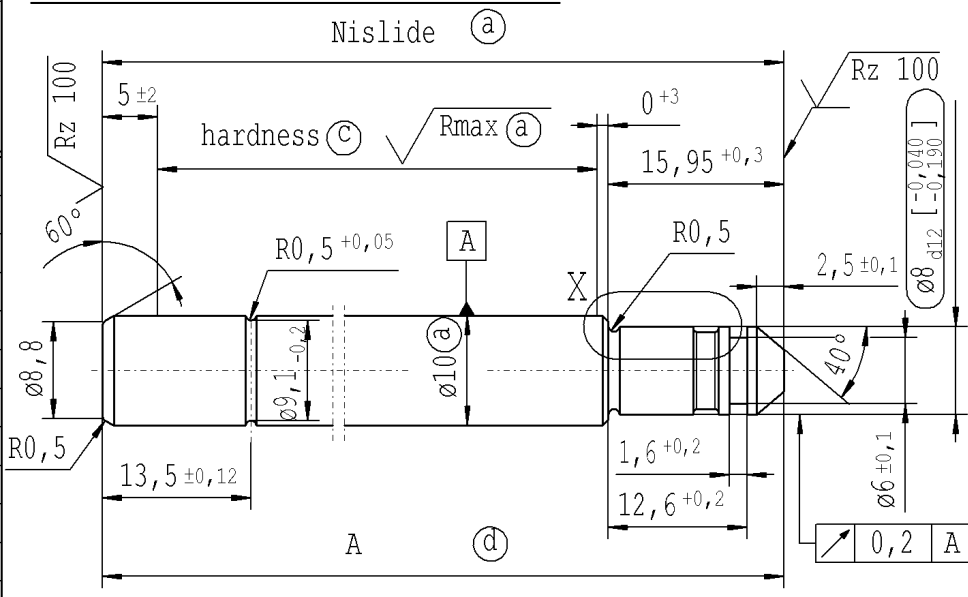

Version 2 (only external manufacturing)

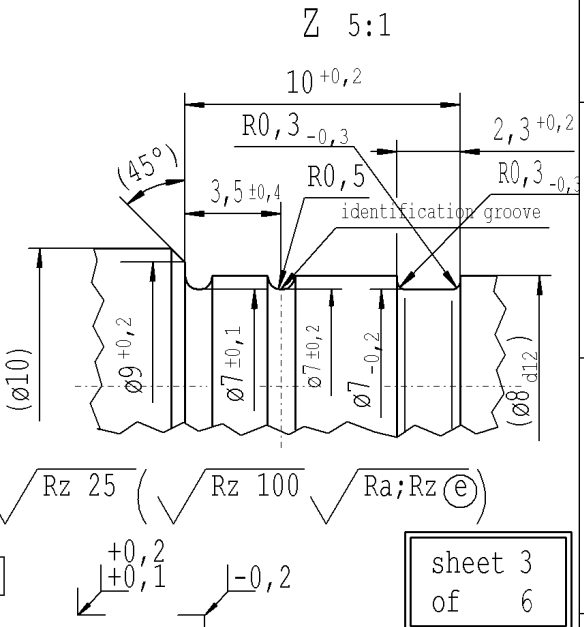
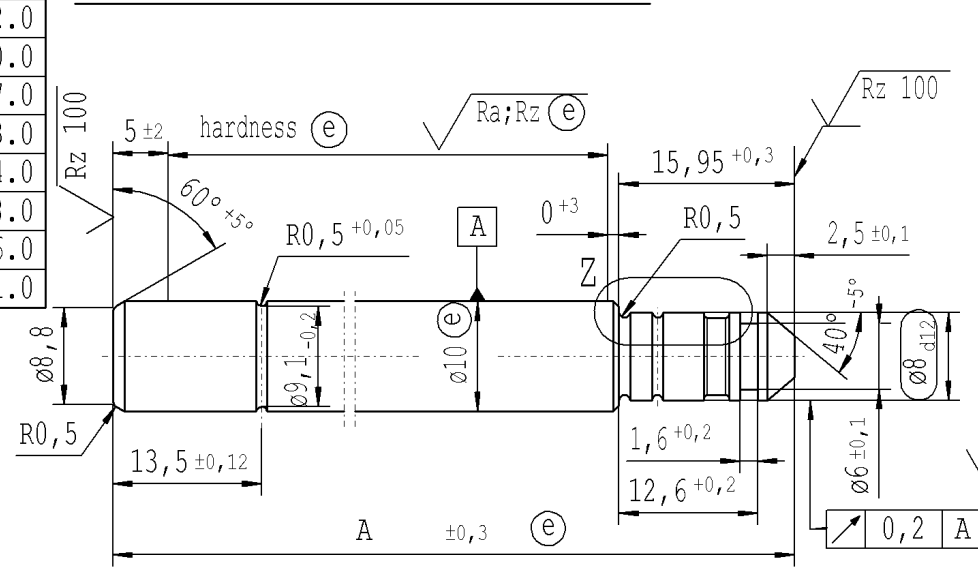

Ⓒ before grinding:
Hardness depth and hardness test acc. to STAB-Spec. 10258370

Ⓓ tolerance $\begin{matrix} +0,2 \\ -0,1 \end{matrix}$ after turning
 $\pm 0,3$ after straightening
 $\pm 0,3$ after nisliding

Environmental protection acc. to STAB-Spec. 10005649

| | | | | | | | |
|-----------|---------------|---------------------|---|------------------------------|------------------------------|-------|---|
| DE: X | EN: X | ES: | IT: | PR: | FR: | RO: X | CAD created document; handwritten changes not permitted |
| new | 3,5±0,4 | .8619TK | 8652TV;8717YN;90527B;90877M;9658PX;2492UB;1511VY;7788VU | Ⓒ = acc. STAB-Spec. 10258370 | new format Internal/Supplier | | |
| old | 3,5±0,2 | DOK 10023735 Pos.29 | was on Dok.10023735 | Ⓒ = RHT 0,4 0,7 mm | Supplier drawing separately | | |
| Field | E2 | Pos.28 | Tab.Pos. 29-36 | B 7-8 | - | | |
| Date/Name | 25.10.06 Keß. | 12.01.2007 Hß | 24.4.07 Reb. | 14.05.2019 Jablonski | 10.02.2021 Jablonski | | |
| Chg. No. | 548667 | 554410 | 556213 | 678684 | 695144 | | |
| Rev. | 4 | 5 | 6 | 7 | 8 | | |

| | | | | |
|--|---------------------------------|--|------------|-----------|
| Material: Version 1: Mat.No. 010715 Version 2 : 1.1193 | All dimensions are in mm | Marking of special characteristics according to STAB-Spec. 10270932 | Date | Name |
| Edge tolerances acc. to DIN ISO 13715 | Scale: (Original DIN A3) 2:1 | Dimensions without tolerances DIN ISO 2768 mK | 11.02.2005 | Keßelheim |
| Surface finish DIN EN ISO 1302 | Replaces: | We reserve all rights to this document, to any patents or patent registrations related hereto, and to the duplication, retransmission by third parties and misc. use. Any use of this document is not permitted without the written consent of STABILUS. | 10.02.2021 | C.Banciu |
| | STABILUS | | | |

| | |
|----------------------------------|---------------|
| Document No.: 10028756 | Material No.: |
| PISTON ROD | |

sheet 3 of 6