

The print-out is not subject to the modification service.

Intended for internal and supplier use

EN

Breveldatum: 30/11/2021 - 9:50

Ident. Doc.:

supp No.	material no.			A	E
	10006248 Tab. XVI optimized version 1	10006248 Tab. X version 1	10028959 Tab. I version 2	overall length	length without endfitting stud
190	402968	402968	402968	306.0	297.5
191	403207	403207	403207	177.0	168.5
192	747845	747845	747845	333.0	324.5
193	902956	902956	902956	348.0	339.5
194	547086	547086	547086	111.0	102.5
195		692159	692159	309.0	300.5
196	694310	694310	694310	366.0	357.5
197	307848	307848	307848	334.0	325.5
198	529879	529879	529879	162.0	153.5
199	227068	227068	227068	315.0	306.5
200	248578	248578	248578	261.0	252.5
201	869261	869261	869261	105.0	96.5
202	103267	103267	103267	369.0	360.5
203	223723	223723	223723	186.0	177.5
207	056186	056186	056186	212.5	204.0
210	356610	356610	356610	417.0	408.5
211	859228	859228	859228	357.0	348.5
212	236873	236873	236873	203.0	194.5
213	723716	723716	723716	156.0	147.5

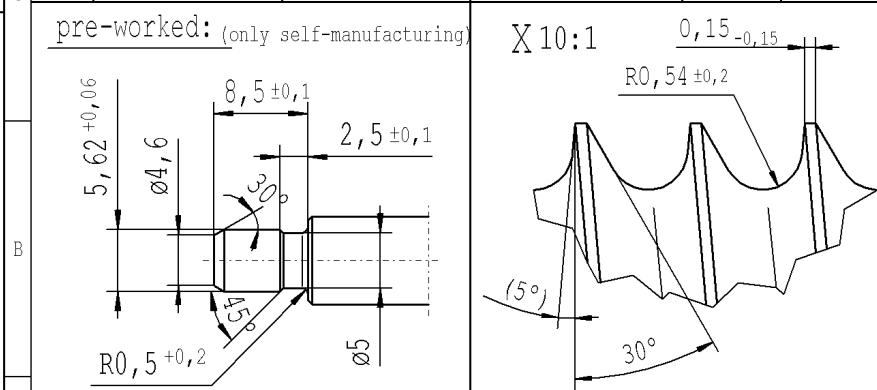

pre-worked: (only self-manufacturing) X 10:1

DE: X	EN: X	ES:	IT:	PR: X	FR:	RO: X	CAD created document; handwritten changes not permitted	Material: *	All dimensions are in mm	Marking of special characteristics according to STAB-Spec. 10270932	Date	Name
new	(5°); no technical change, no new first sample required						Tab XVI; no technical change, no new first sample required		Scale: (Original DIN A3) 2:1	Dimensions without tolerances DIN ISO 2768-mK	Drawn by	Höfer
old				5°			Tab IV;	Edge tolerances acc. to DIN ISO 13715			Checked	Milles
Field				B/6-7			F 8	Surface finish DIN EN ISO 1302	We reserve all rights to this document, to any patents or patent registrations related hereto, and to the duplication, retransmission by third parties and misc. use. Any use of this document is not permitted without the written consent of STABILUS.			Document No.:
Date/Name				31.03.2021 Hein			12.08.2021 Donat	Replaces:				10151065
Chg. No.				696924			699704					Material No.:
Rev.				21			21					

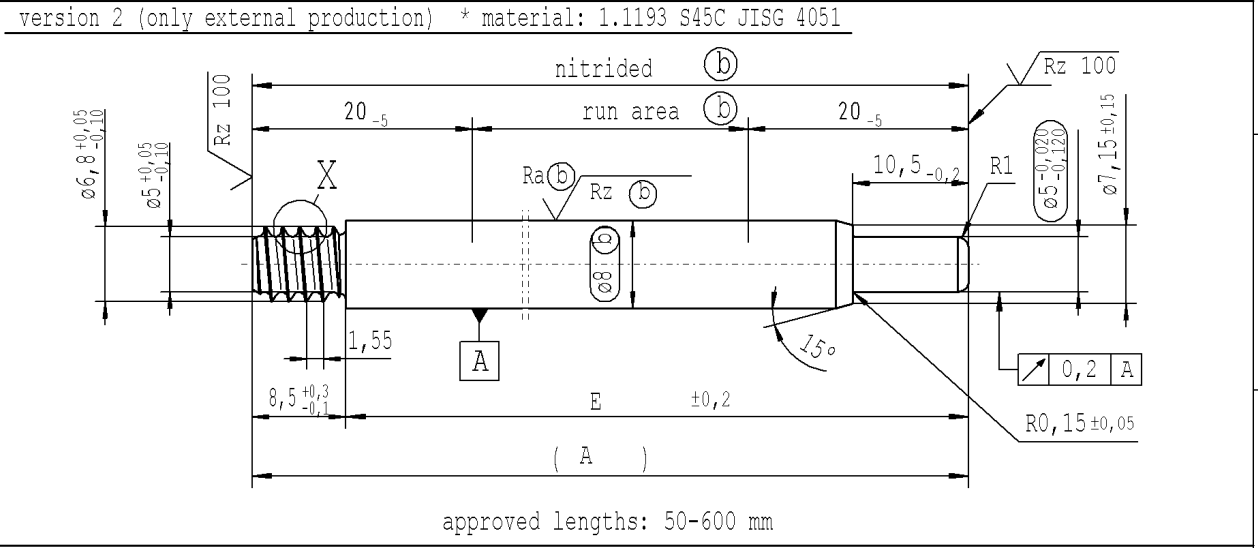
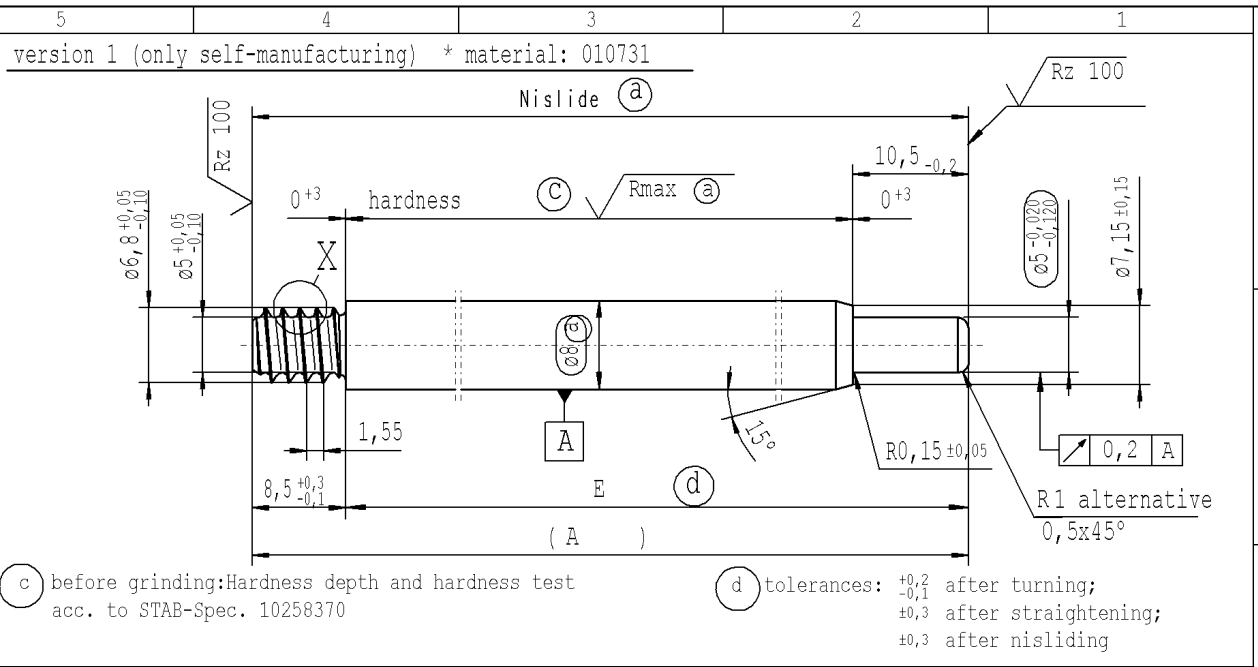

√ Rz 25 (√ Rz 100 √ Rmax (a) Ra (b) Rz (b)) ± 0,2 ∓ 0,2

sheet 10 of 16

STABILUS

PISTON ROD