

The print-out is not subject to the modification service.

Intended for internal and supplier use

EN

Ident. Doc.:

Date/Name: 06.12.2021 / 15:16:21 ***** Ausdruck nicht massgetreu *****

supp No.	material no.				A	B
	processing and surface treatment acc. to STAB-Spec.				overall length	thread length
	10006248 Tab. XVI optimized version 1	10006248 Tab. V version 1	10006248 Tab. X version 1	10028959 Tab. I version 2		
24	322461		322461	322461	300.0	10
25	332499		332499	332499	192.0	10
26	340147		340147	340147	249.0	10
27	348990		348990	348990	219.0	10
28	350663		350663	350663	99.0	10
29	352814		352814	352814	156.0	10
30	362613		362613	362613	124.0	10
31	363569		363569	363569	138.0	10
32	376953		376953	376953	456.0	10
33	377431		377431	377431	186.0	6
34	387708		387708	387708	255.0	10
35	396312		396312	396312	111.0	10
36	398702		398702	398702	228.0	10
37	420451		420451	420451	135.0	10
38	421168		421168	421168	177.0	10
39	425948		425948	425948	126.0	10
40	427621		427621	427621	195.0	10
41	437659		437659	437659	117.0	10
42	457018		457018	457018	114.0	10
43	457974		457974	457974	243.0	10

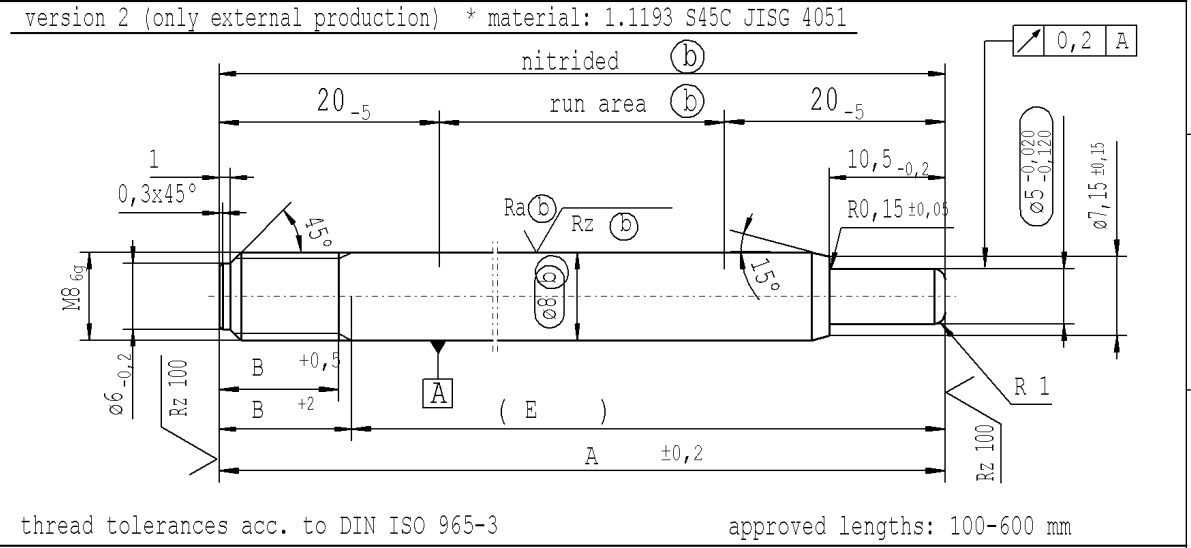
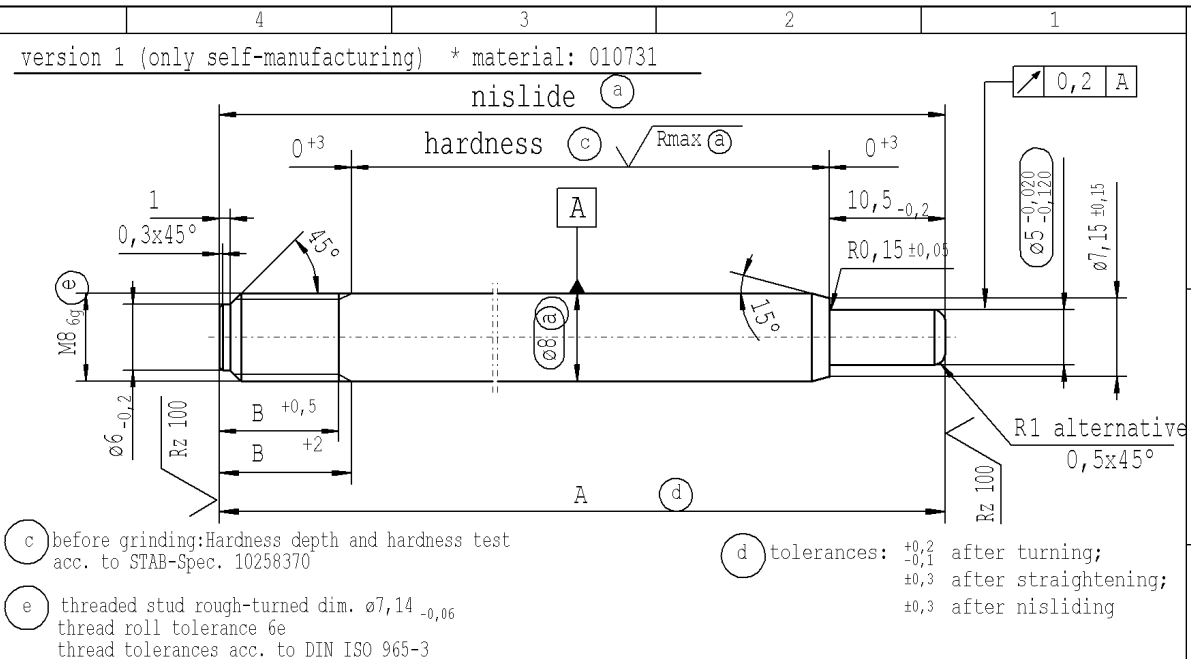

AIAG CQI-standards acc. to STAB-Spec. 10027692				Environmental protection acc. to STAB-Spec. 10005649			
DE: X	EN: X	ES:	IT:	PR:	FR:	RO: X	CAD created document; handwritten changes not permitted
new	© = acc. STAB-Spec. 10258370	new format Internal/Supplier		Tab XVI; no technical change, no new first sample required			
old	© = RHT 0,4 ... 0,7 mm	Supplier drawing separately		Tab IV;			
Field	C8	-		F 8			
Date/Name	06.06.2019 Höfer	17.09.2020 Donat		16.08.2021 Donat			
Chg. No.	678546	691413		699704			
Rev.	6	7		7			
Material: *				All dimensions are in mm			
Edge tolerances acc. to DIN ISO 13715				Scale: (Original DIN A3) 2:1			
Surface finish DIN EN ISO 1302				Marking of special characteristics according to STAB-Spec. 10270932			
Replaces:				We reserve all rights to this document, to any patents or patent registrations related hereto, and to the duplication, retransmission by third parties and misc. use. Any use of this document is not permitted without the written consent of STABILUS.			
STABILUS				PISTON ROD			
				Date: 05.03.2014 Name: Höfer			
				Checked: 16.08.2021 Milles			
				Document No.: 10210124			
				Material No.:			

sheet 2 of 4