

The print-out is not subject to the modification service.

Intended for internal and supplier use

Ident. Doc. :  
Date: 4/10/2022 - 6:23

	8	7	6	5	4	3	2	1
supp. No.	material no.	A	B					
	Surface treatment STAB-Spec. 10028959 Tab.I (b)	overall length	stud length piston side					
X	xxxxxxx	324	11					

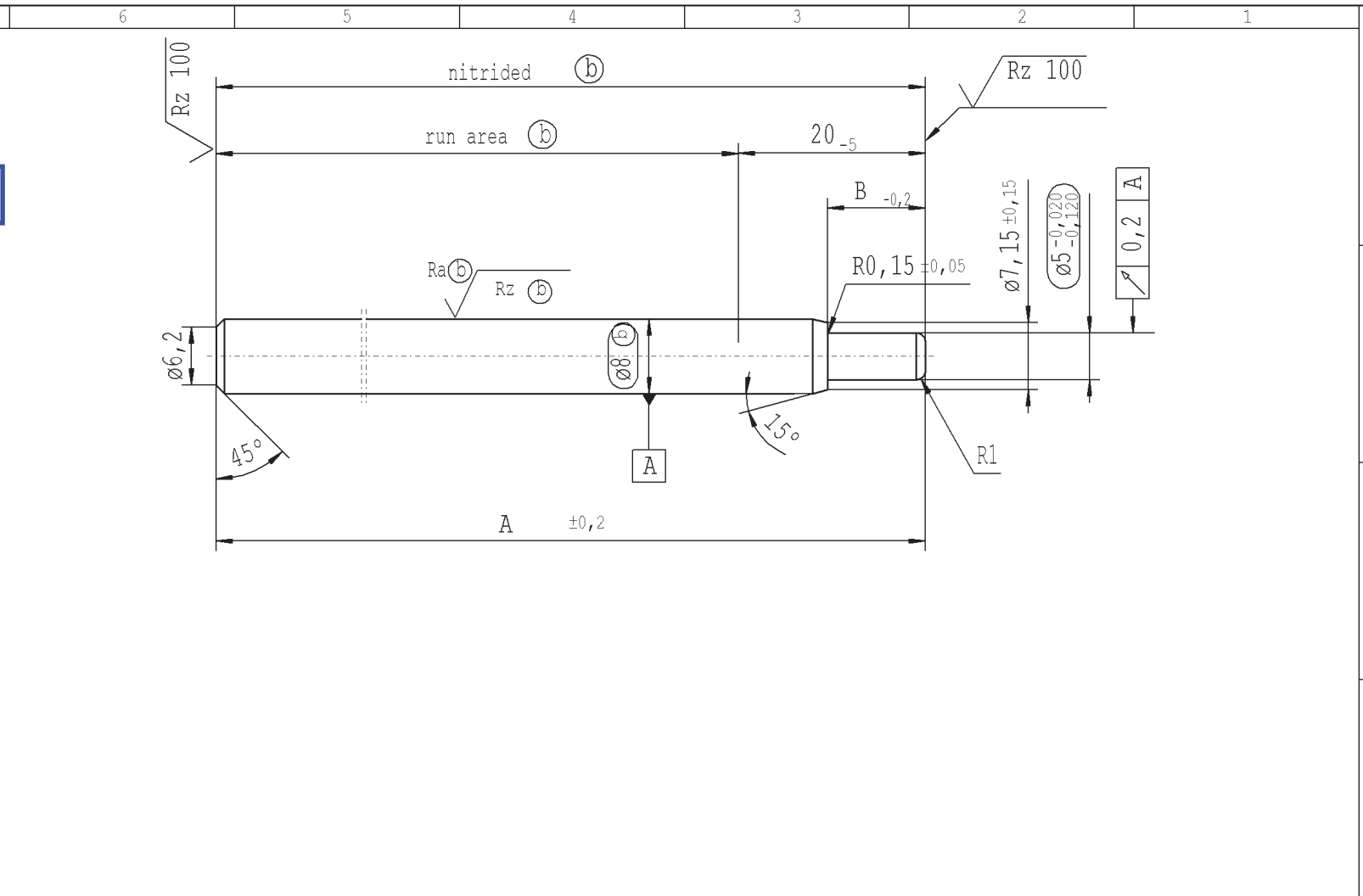

external production \* material: 1.1193 S45C JISG 4051  
 approved lengths: 50-600 mm

Surface finish symbols:  $\sqrt{Rz 25}$  ( $\sqrt{Rz 100}$   $Ra(b)$   $Rz(b)$ )  $\swarrow +0,2$   $\searrow -0,2$

Signature:

sheet 1  
of 1

DE: X	EN: X	ES:	IT:	PR:	FR:	RO: X
new	INITIAL RELEASE					
old	-					
Field	-					
Date/Name	04.10.2022 Jablonski					
Chg. No.	-					
Rev.	0					

AIAG CQI-standards acc. to STAB-Spec. 10027692		Material: *	All dimensions are in mm	Marking of special characteristics according to STAB-Spec. 10270932
CAD created document; handwritten changes not permitted		Edge tolerances acc. to DIN ISO 13715	Scale: (Original DIN A3) 2:1	Dimensions without tolerances DIN ISO 2768 mK
		Surface finish DIN EN ISO 1302	We reserve all rights to this document, to any patents or patent registrations related hereto, and to the duplication, retransmission by third parties and misc. use. Any use of this document is not permitted without the written consent of STABILUS.	
		Replaces:	Document No.: 10312767	
		<b>STABILUS</b>	Material No.:	
			<b>PISTON ROD</b>	

Environmental protection acc. to STAB-Spec. 10005649		
Date	Name	
04.10.2022	Jablonski	
Checked	Zaharia	
Document No.: 10312767		
Material No.:		